

### MPV1 & MPV2

#### Specifications

##### Electrical

Supply voltage	15 - 24 VDC
Supply current	350 mA
Command signal	0 - 10 VDC   4 - 20 mA
Command signal impedance	VDC = 4.75 kΩ   Current = 100Ω
Monitor signal	0 - 10 VDC

##### Mechanical

Pressure range†	Vacuum - 150 psig (760 mmHg (Vac) - 12 Bar)
Output pressure	0 - 100% of range
Flow rate	Varies with inlet valve. See ordering information.
Port size	1/8" NPT
Min closed end volume	1 in <sup>3</sup>
Filtration recommended	40 Micron (included)
Linearity/Hysteresis	<±0.02% F.S. BFSL
Repeatability	<±0.02% F.S.
Accuracy	<±0.2% F.S.
Resolution	Up to ±0.005% F.S.

##### Wetted Parts ‡

Elastomers	Fluorocarbon
Manifold	Brass
Valves	Nickel plated brass
Pressure transducer	Silicon, aluminum

##### Physical

Operating temperature	32 - 158°F (0 - 70°C) 1
Weight	lbs (0.45 kg)

† Pressure ranges are customer specified. Output pressures other than 100% are available. ‡ Others available.

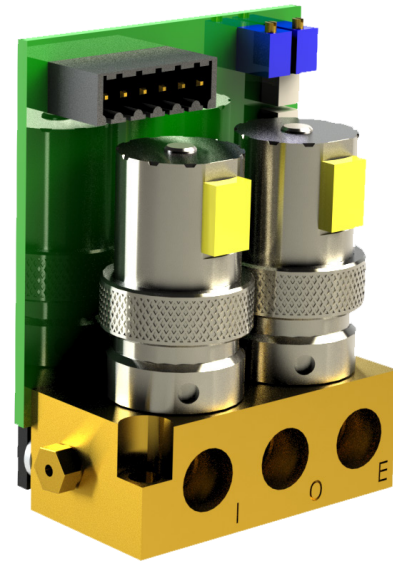

#### Description

The MPV series valve uses closed loop technology for pressure control. It gives an output pressure proportional to an electrical command signal input.

The MPV is a high resolution pressure regulator consisting of valves, manifold, and electronic controls. Pressure is controlled by the use of two valves; one is a typical ON/OFF solenoid and the other is a variable orifice valve. The variable orifice valve functions as inlet control, the other as exhaust. The inlet valve operates proportionally to the command supplied by the control circuit. This variable orifice effect allows precise control of pressure at low flow conditions and avoids the digital steps of traditional ON/OFF solenoids. The exhaust solenoid allows excess media to be vented from the system.

The pressure output is measured by an internal pressure transducer and provides a feedback signal to the electronic controls. An MPV2 uses an external pressure transducer to maintain pressure downstream should the application need to be further downstream from the MPV. This external feedback is sent to the electronic controls. This feedback signal is compared with the command signal input. A difference between the two signals causes one of the valves to open, allowing flow in or out of the system. Accurate pressure is maintained by controlling these two valves.

A monitor output is provided for the system measurement. All MPV valves come standard with an analog voltage monitor output. MPV1 monitor output is an amplified signal from the internal pressure transducer.

#### WARNING

These products are intended for use in industrial compressed gas systems only. Do not use these products where pressures and temperatures exceed the specifications listed.

# INSTALLATION

## DIN Rail Mount

The DIN rail MPV valve comes assembled to a DIN rail with a universal foot to allow all modules to be snapped onto all available DIN footprints:

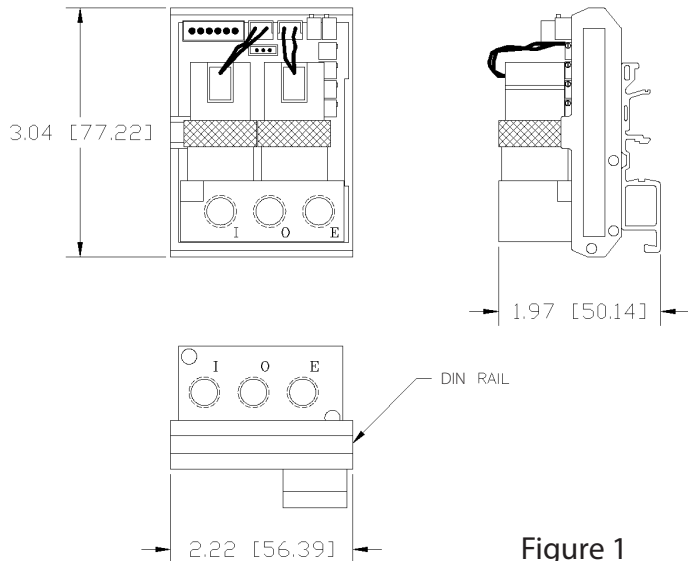

## Panel Mount

The panel mount MPV valve can be assembled to a panel by inserting two 8-32 socket head cap screws into the manifold and torque each screw into the panel (FIG. 2).

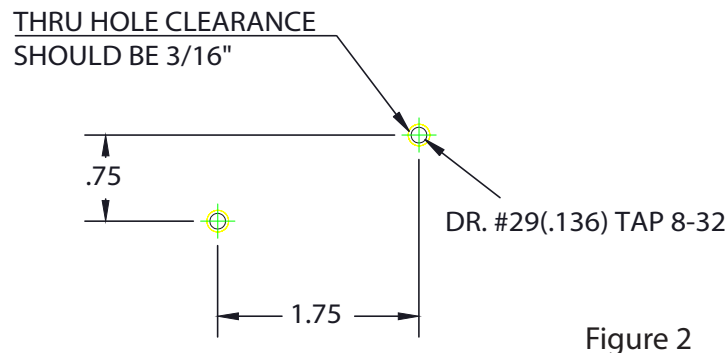

## Manifold Mount

1. Install the three O-rings in the O-ring grooves of the sub-base manifold.
2. Align the MPV control valve over the three O-rings. Orientation of the MPV unit should be the same for all MPVs on the manifold and can be determined by the "I" and "E" marks on the MPV brass manifold and the aluminum sub-base manifold .
3. Insert the two cap screws that hold the valve to the sub-base manifold. Torque each screw to 8 in-lbs. and then torque each cap screw to 13-15 in-lbs.
4. To install the sub-base manifold to a panel use 1/4-20 socket head mounting screws.

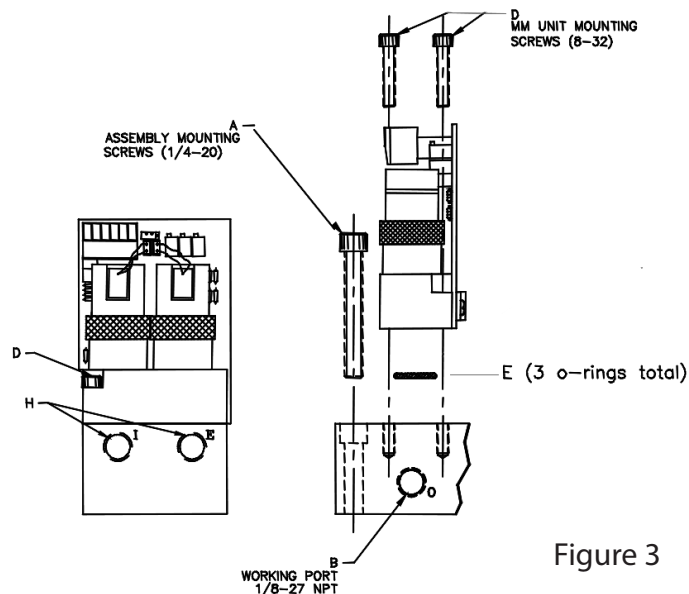

# PNEUMATIC CONNECTONS

1. **THIS STEP ONLY APPLIES FOR UNITS THAT ARE NOT MANIFOLD MOUNTED TO A SUB-BASE.** Apply a small amount of anaerobic sealant to the male threads of the in-line filter supplied with the MPV.
2. Connect supply pressure to port labeled I; not to exceed rated supply pressure (TABLE 2).
3. For vacuum units, the vacuum supply must be connected to the exhaust E port.
4. Connect the outlet O port to the device being controlled.

# ELECTRICAL CONNECTONS

1. Ensure all power is off.
2. See the chart below for a
3. Identify the valve's command input and monitor output by referring to the calibration card.
4. Proceed to the section that relates to electrical connections as found on calibration card.

Table 1	
Connector Label	Function
V-	DC Common
V+	DC Power
C+	Command +
C-	Command -
M	Monitor
E	2nd Loop In

## Command Signal (E, K, V)

All voltage command MPVs use common mode voltage, meaning the DC Common pin is the common reference for both power and command. FIG. 4 shows the proper command connections.

<b>V-</b> DC Common (Power & Command)	<b>V+</b> DC Power	<b>C+</b> 0-10 VDC Command	<b>C-</b>	<b>M</b>	<b>E</b>
---	-----------------------	----------------------------------	-----------	----------	----------

Figure 4

## Monitor Signal (E, K, V)

Use the following wiring diagram for MPV units with voltage monitor feedback. FIG. 6 shows how to connect the voltmeter in parallel with the monitor output and ground.

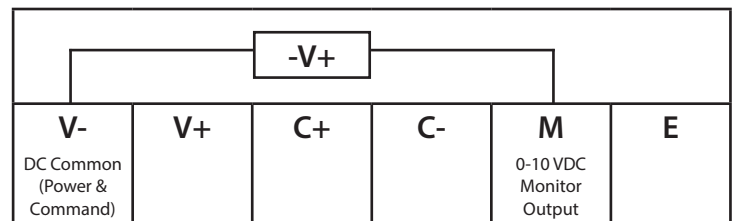

Figure 6

## Command Signal (I)

All current command MPVs use a differential current loop scheme, meaning current flow is from C+ to C- on the MPV valves. FIG. 5 shows proper electrical connections for current command valves.

<b>V-</b> DC Common (Power & Command)	<b>V+</b> DC Power	<b>C+</b> 4-20 mA Command	<b>C-</b> 4-20 mA Return	<b>M</b>	<b>E</b>
---	-----------------------	---------------------------------	--------------------------------	----------	----------

Figure 5

## MPV2 Second Loop

All MPV2 valves are designed to accept a 0-10VDC second loop input signal. Wire the external feedback signal to pin E on the electrical connector. FIG. 7 shows where to connect the external feedback to the connector. NOTE: If using external feedback, transducer output must match pressure controller calibration.

<b>V-</b>	<b>V+</b>	<b>C+</b>	<b>C-</b>	<b>M</b>	<b>E</b> 0-10 VDC 2nd Loop Feedback
-----------	-----------	-----------	-----------	----------	--

Figure 7

# RECALIBRATION PROCEDURE

All MPV valves come pre-calibrated from the factory using precision calibration equipment. If the MPV valve needs re-calibration, use the procedure described below:

1. Wire control valve according to the section titled "Electrical Connections."
2. Connect a precision measuring gauge or transducer to the outlet port of the MPV. **NOTE: THERE MUST BE A CLOSED VOLUME OF AT LEAST 1 CU. IN BETWEEN THE VALVE OUTLET AND THE MEASURING DEVICE FOR VALVE TO BE STABLE.**
3. Plumb control valve according to section titled "Pneumatic Connections". Make sure supply pressure does not exceed the rating for the valve (TABLE 2).
4. On the printed circuit board, locate the two adjustment potentiometers labeled S (span adjust) and Z (zero adjust).
5. **ONLY USE THIS STEP IF DEVICE IS COMPLETELY OUT OF CALIBRATION. IF IT IS SLIGHTLY OUT OF CALIBRATION, PROCEED TO STEP 6.** With a small screwdriver, turn both potentiometers 15 turns clockwise. Then turn them 7 turns counter clockwise. This will put the MPV roughly at mid scale
6. Set the electrical command input to MAXIMUM value.
7. Adjust the SPAN potentiometer until MAXIMUM desired pressure or vacuum is reached (clockwise to increase pressure).
8. Set the electrical command input to 10 percent of full value (1Vdc for 0-10Vdc unit or 5.6mA for 4-20mA unit).
9. Adjust the ZERO potentiometer until 10 percent of maximum desired pressure or vacuum is reached. (clockwise increases pressure).
10. If at any time during the calibration procedure the control valve oscillates or becomes unstable for more than one second, turn the hysteresis potentiometer labeled H clockwise until the oscillation stops, then turn it one more complete turn (same direction).
11. The ZERO and SPAN potentiometers interact slightly. Repeat steps 5-10 until no error exists.
12. Verify unit shuts off by going to zero command. Check linearity by going to at least six pressure points throughout the full range.

Max Calibrated Pressure	Max Inlet Pressure
-1 - 1 psig	Consult factory
Vacuum - 30 psig	35 psig
31 - 100 psig	110 psig
101 - 150 psig	165 psig

# DIMENSIONS

## PANEL MOUNT

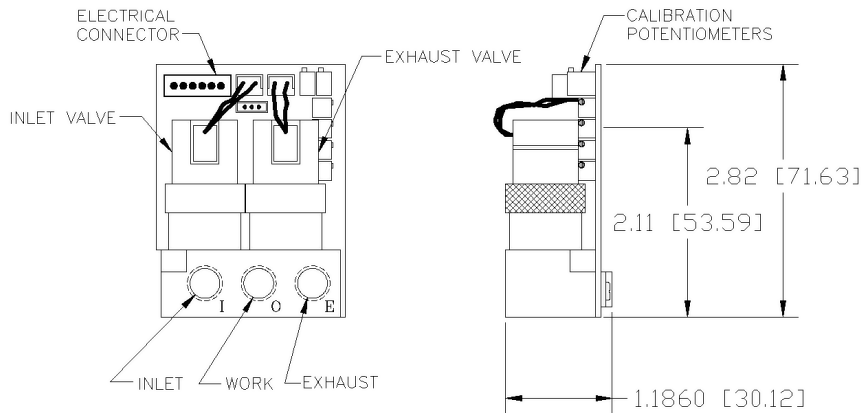

Figure 8

## DIN RAIL MOUNT

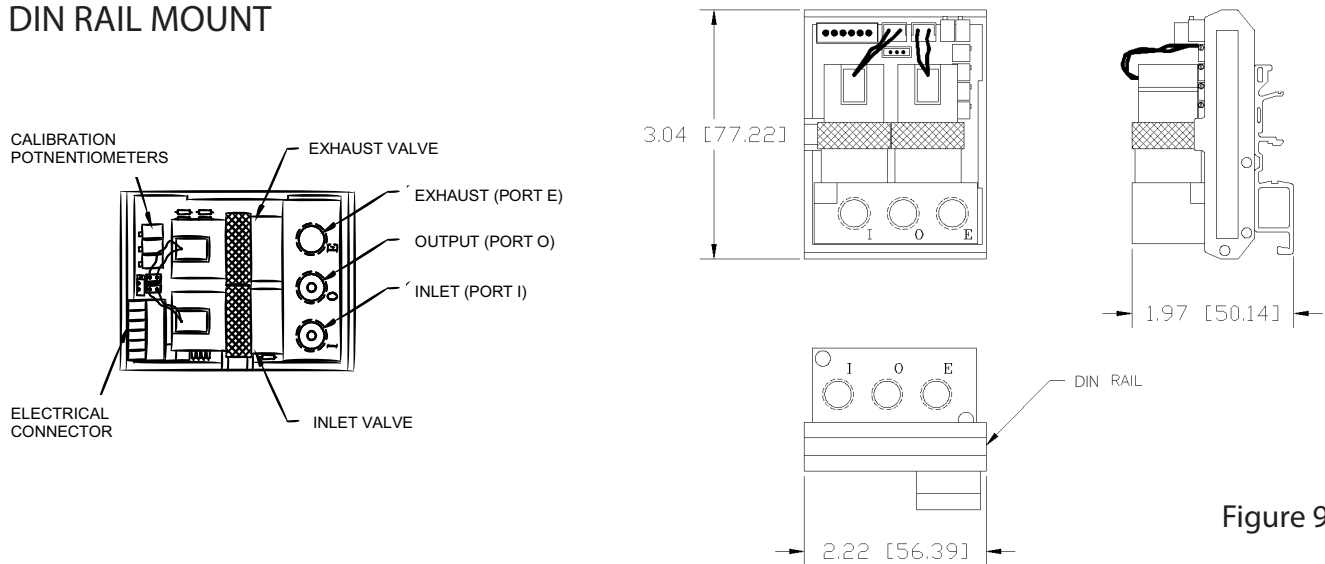

Figure 9

## MANIFOLD MOUNT

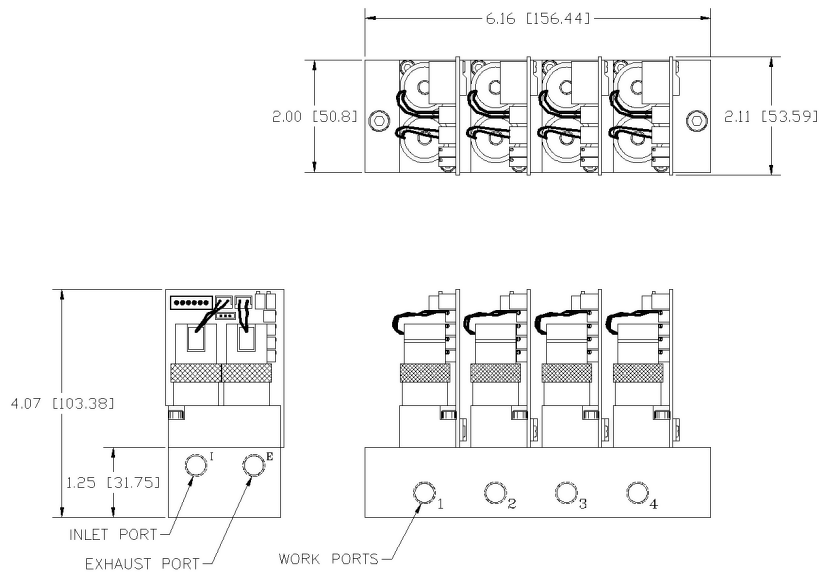

Figure 10

**Notes:**

1. All dimensions are in inches
2. All dimensions are for reference only.

# CONFIGURATION

## MPV

<b>ACCURACY</b>	±0.2% F.S.	<b>PRESSURE</b>	Full Vac to 150 PSIG (10 Bar)	<b>MOUNTING OPTIONS</b>	1. DIN Rail Mount 2. Panel Mount 3. Manifold Mount (up to 12)
<b>PORT SIZE</b>	1/8"	<b>MAX FLOW</b>	1 SCFM (28 SLPM)		

Example Part Number	MPV	1	D	B	N	E	E	Z		P	5	BR	G	B	X	L			
Section Reference ->		1	2	3	4	5	6	7	8	9	10	11	12	13	14	15	OPTIONS		

1 Type
1 Single Loop
2 Dual Loop

2 Mounting Type
D DIN Rail (Ports on Face)
M Manifold (Ports on Bottom)
P Panel (Ports on Face)

3 Manifold Material
A Anodized Aluminum
B Brass (typical)

4 Thread Type
N NPT
P BSPP
H Manifold Mount (no threads)

5 Command Signal Range
E 0 to 10 VDC
I 4 to 20 mA DC
K 0 to 5 VDC
V 1 to 5 VDC (Requires V for Monitor Signal #6)

6 Monitor Signal Range
X No Monitor
E 0 to 10 VDC
K 0 to 5 VDC (Requires E, I or K for Command Signal Range #5)
V 1 to 5 VDC (Requires V for Command Signal Range #5)

11 Pressure Unit			
PS PSI		Inches Hg	IH
MB Millibars		Inches H <sub>2</sub> O	IW
BR Bar		Millimeters H <sub>2</sub> O	MW
KP Kilo-pascal		Kilograms/cm <sup>2</sup>	KG
MP Mega-pascal		Torr (Requires A for Unit of Measure #12)	TR
MH Millimeters Hg		Centimeters H <sub>2</sub> O	CW
PA Pascal			

13 Inlet Valve	
A 0.013" (proportional valve)	
B 0.025" (proportional valve)	
C 0.040" (proportional valve)	
D 0.060" (proportional valve)	
E 0.089" (proportional valve)	
N No Inlet Valve*	
X 0.040"* (digital valve)	
*Vacuum Pressure Units Only	

14 Outlet Valve	
A 0.013"* (proportional valve)	
B 0.025"* (proportional valve)	
C 0.040"* (proportional valve)	
D 0.060"* (proportional valve)	
E 0.089"* (proportional valve)	
N No Exhaust Valve	
X 0.040"* (digital valve)	
*Vacuum Pressure Units Only	

15 Bleed Orifice
N No Bleed Orifice
L Factory Standard Bleed Orifice (0.004")
Z Non-Standard Bleed Orifice (0.002")

Options
BR Foot-Mounted Bracket + Install
DR Install DIN Rail Mounting Kit
O2* Oxygen Cleaned
O3 Oxygen Cleaned No O2
P1 12-VDC Power

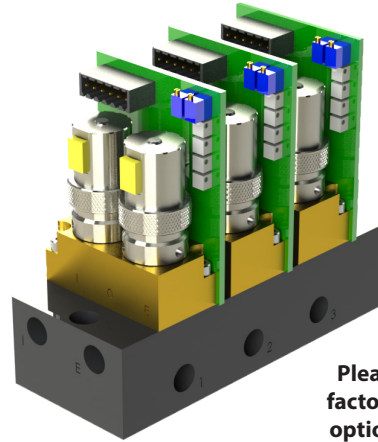

Please consult the factory for manifold options and pricing

7 Zero Offset
N 0% Pressure is Below Zero
P 0% Pressure is Above Zero
Z 0% Pressure is Zero (Typical)

9 Full Scale Pressure Type
N 100% Pressure is Below Zero
P 100% Pressure is Above Zero
Z 100% Pressure is Zero

8 Zero Offset Pressure
Typical is 0% - If greater than 30% of full scale pressure (#9), please consult factory.
*If Z for Zero Offset, Please Leave this Section (#7) Blank

10 Full Scale Pressure
Must be between less than or equal to 150 psig*
*Adder if Full Scale Pressure is <13.5" H2O

12 Pressure Unit of Measure
A Absolute Pressure
D Differential Pressure
G Gauge Pressure

**PLEASE CONTACT FACTORY FOR VALVE & ORIFICE SELECTION**

Inlet valve orifice size and the exhaust valve are factory determined based on the application's flow and pressure specs. Bleed orifice is required when the MPV is used in an application that is static (no flow). Dynamic applications (under flow) do not require a bleed orifice to function properly. Please consult our Applications Team for your specific application needs. We are here to help you.

\*O2 cleaning only available on brass manifold. Many other options are available. Please consult factory for more information.

## **SAFETY PRECAUTIONS**

*Please read the following safety information before installing or operating any Proportion-Air, Inc. equipment or accessories. To confirm safety, observe 'ISO 4414: Pneumatic Fluid Power - General rules relating to systems' and other safety practices.*

### **WARNING**

Improper operation could result in serious injury or loss of life!

#### **1. PRODUCT COMPATIBILITY**

Proportion-Air, Inc. products and accessories are for use in industrial pneumatic applications with compressed air media. The compatibility of the equipment is the responsibility of the end user. Product performance and safety are the responsibility of the person who determined the compatibility of the system. Also, this person is responsible for continuously reviewing the suitability of the products specified for the system, referencing the latest catalog, installation manual, Safety Precautions and all materials related to the product.

#### **2. EMERGENCY SHUTOFF**

Proportion, Inc. products cannot be used as an emergency shutoff. A redundant safety system should be installed in the system to prevent serious injury or loss of life.

#### **3. EXPLOSIVE ATMOSPHERES**

Products and equipment should not be used where harmful, corrosive or explosive materials or gases are present. Unless certified, Proportion-Air, Inc. products cannot be used with flammable gases or in hazardous environments.

#### **4. AIR QUALITY**

Clean, dry air is not required for Proportion-Air, Inc. products. However, a 40 micron particulate filter is recommended to prevent solid contamination from entering the product.

#### **5. TEMPERATURE**

Products should be used with a media and ambient environment inside of the specified temperature range of 32°F to 158°F. Consult factory for expanded temperature ranges.

#### **6. OPERATION**

Only trained and certified personnel should operate electronic and pneumatic machinery and equipment. Electronics and pneumatics are very dangerous when handled incorrectly. All industry standard safety guidelines should be observed.

#### **7. SERVICE AND MAINTENANCE**

Service and maintenance of machinery and equipment should only be handled by trained and experienced operators. Inspection should only be performed after safety has been confirmed. Ensure all supply pressure has been exhausted and residual energy (compressed gas, springs, gravity, etc.) has been released in the entire system prior to removing equipment for service or maintenance.

### **CAUTION**

Improper operation could result in serious injury to people or damage to equipment!

#### **1. PNEUMATIC CONNECTION**

All pipes, pneumatic hose and tubing should be free of all contamination, debris and chips prior to installation. Flush pipes with compressed air to remove any loose particles.

#### **2. THREAD SEALANT**

To prevent product contamination, thread tape is not recommended. Instead, a non-migrating thread sealant is recommended for installation. Apply sealant a couple threads from the end of the pipe thread to prevent contamination.

#### **3. ELECTRICAL CONNECTION**

To prevent electronic damage, all electrical specifications should be reviewed and all electrical connections should be verified prior to operation.

### **EXEMPTION FROM LIABILITY**

**1. Proportion-Air, Inc.** is exempted from any damages resulting from any operations not contained within the catalogs and/or instruction manuals and operations outside the range of its product specifications.

**2. Proportion-Air, Inc.** is exempted from any damage or loss whatsoever caused by malfunctions of its products when combined with other devices or software.

**3. Proportion-Air, Inc.** and its employees shall be exempted from any damage or loss resulting from earthquakes, fire, third person actions, accidents, intentional or unintentional operator error, product misapplication or irregular operating conditions.

**4. Proportion-Air, Inc.** and its employees shall be exempted from any damage or loss, either direct or indirect, including consequential damage or loss, claims, proceedings, demands, costs, expenses, judgments, awards, loss of profits or loss of chance and any other liability whatsoever including legal expenses and costs, which may be suffered or incurred, whether in tort (including negligence), contract, breach of statutory duty, equity or otherwise.

### **WARRANTY**

Proportion-Air, Inc. products are warranted to the original purchaser only against defects in material or workmanship for eighteen (18) months from the date of manufacture. The extent of Proportion-Air's liability under this warranty is limited to repair or replacement of the defective unit at Proportion-Air's option. Proportion-Air shall have no liability under this warranty where improper installation or filtration occurred.

# **PROPORTION**

ProportionAir.com

8250 N 600 W

P.O. Box 218

McCordsville, IN 46055

*info@proportionair.com*

Handcrafted in the USA  
ISO 9001-2015 Certified