

### QB3H

#### Specifications

##### Electrical

Supply voltage	15 - 24 VDC
Supply current	250 mA max
Command signal ‡	0 - 10 VDC   4 - 20 mA
Command signal impedance	VDC = 10 kΩ   Current = 100Ω
Voltage monitor signal	0 - 10 VDC @ 10 mA max
Current monitor signal	4 - 20 mA Sinking or Sourcing

##### Mechanical

Pressure ranges †	Vacuum - 500 psig (760 mmHg (Vac) - 34.7 Bar)
Output pressure	0 - 100% of range
Flow rate	50 SCFM (1,416 L/min)
Port size	3/8" NPT
Min closed end volume	3 in <sup>3</sup>
Filtration recommended	40 Micron
Linearity/Hysteresis	<±0.5% F.S. BFSL
Repeatability	<±0.2% F.S.
Accuracy	<±0.5% F.S.

##### Wetted Parts ‡

Elastomers	Buna-N
Manifold	Nickel plated brass or aluminum
Valves	Nickel plated brass
Pressure transducer	17-4 ph Stainless steel

##### Physical

Operating temperature	32 - 158°F (0 - 70°C)
Weight	1.4 lbs (0.64 kg) - Aluminum 2.8 lbs (1.27 kg) - Brass
Protection rating	IP 65
Housing	Aluminum (anodized)

† Pressure ranges are customer specified. Output pressures other than 100% are available. Vacuum through positive pressure units, pressure must be equal to or greater than vacuum level. Consult factory for pressure ranges below 10 psig.  
‡ Others available.

### WARNING

These products are intended for use in industrial compressed gas systems only. Do not use these products where pressures and temperatures exceed the specifications listed.



#### Description

The QB3H is a closed loop pressure regulator consisting of two solenoid valves, internal pressure transducer, and electronic controls mounted to an integrated mechanical regulator. The pressure is controlled by activating the solenoid valves, which apply pressure to the pilot of the mechanical regulator. One valve functions as inlet control, the other as exhaust. The unit output pressure is measured by a pressure transducer, which is internally mounted to sense pressure in the work port of the QB3H and provides a transduced feedback signal to the electronic control circuit. This feedback signal is compared to the command signal. Differences between the command signal and the actual pressure feedback signal causes one of the solenoid valves to open to adjust the pressure in the pilot of the booster/regulator. Pilot pressure is adjusted so that desired downstream operating pressure is achieved and maintained. Because the working pressure is sensed as opposed to pilot pressure, hysteresis in the integrated mechanical regulator is eliminated.

The output pressure is proportional to an electrical command signal. Command inputs are either a differential 0-10 VDC, 4-20 mA, 0-5 VDC, or 1-5 VDC. The unit comes standard with an electrical monitor signal for tracking pressure which comes from the internal pressure transducer.

The uniqueness of the booster design is that it has no stamped gaskets or special molded diaphragm or seal parts. All of the parts related to normal maintenance are standard O-rings.

# PNEUMATIC CONNECTIONS

CAUTION: USE ONLY THE THREAD SEALANT PROVIDED. OTHER SEALANTS SUCH AS PTFE TAPE AND PIPE DOPE CAN MIGRATE INTO THE FLUID SYSTEM CAUSING FAILURES.

1. The valve can be mounted in any position without affecting performance. Mounting brackets (ordered separately) can be used to attach valve to a panel or wall surface.
2. A typical 40 micron in-line filter is recommended on the inlet of the QB3H valve. This is available from Proportion-Air as part number FPP-3.

## Positive Pressure Units

1. Connect supply pressure to the inlet port (Figure 1) not to exceed the rated supply pressure. (See Table 1)
2. Connect the outlet port (Figure 3) to the device being controlled.
3. The exhaust port can be plumbed to a point outside the work area, fitted with a muffler or left open to atmosphere as the application dictates.
4. Proceed with "Electrical Connections" section.

## Vacuum Only & Vacuum Through Positive Pressure Units

1. Connect vacuum supply to the exhaust port (Figure 2). The auxiliary exhaust port must be plugged with the 1/16" NPT pipe plug provided to prevent atmospheric air from leaking in to the vacuum supply.
2. Connect supply pressure to the inlet port (Figure 1) not to exceed the rated supply pressure. (See Table 1). **Positive supply pressure is required on vacuum and vacuum through positive pressure QB3H units.** (Call factory with questions.)
3. Connect the outlet port (Figure 3) to the device being controlled.
4. Proceed with "Electrical Connections" section.

TABLE 1

Max calibrated pressure:	Max inlet pressure:
Vacuum only	5 psig (0.35 bar)
Vacuum up to 10 psig (0.69 bar)	Consult factory
10.1 - 30 psig (0.70 - 2 bar)	35 psig (2.4 bar)
31 - 100 psig (2.1 - 7 bar)	110 psig (7.6 bar)
101 - 175 psig (7 - 12 bar)	190 psig (13 bar)
176 - 300 psig (12.1 - 20.7 bar)	330 psig (22.8 bar)
301 - 500 psig (20.8 - 34.5 bar)	550 psig (37.9 bar)

# DIMENSIONS

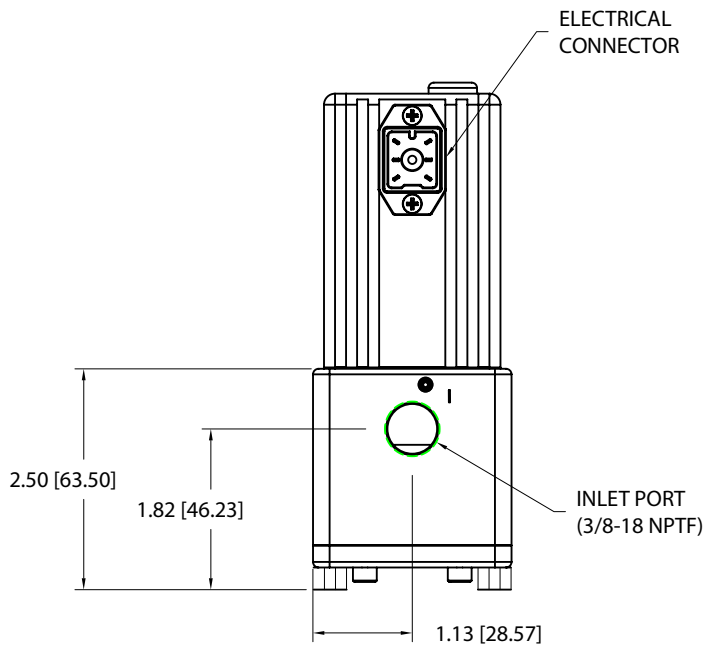

Figure 1

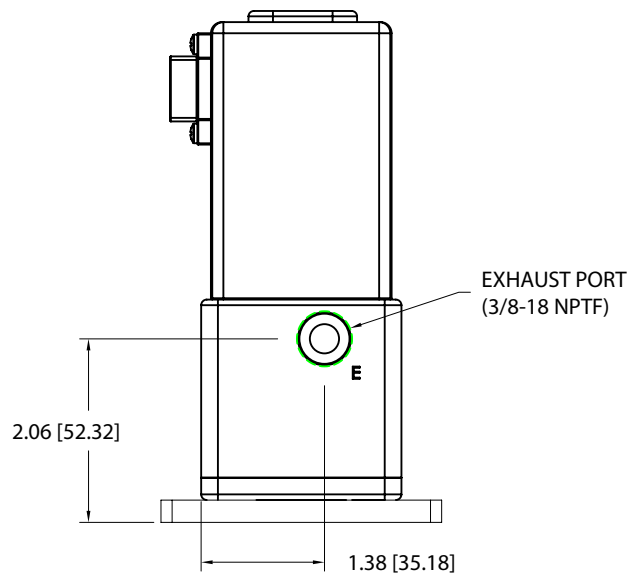

Figure 2

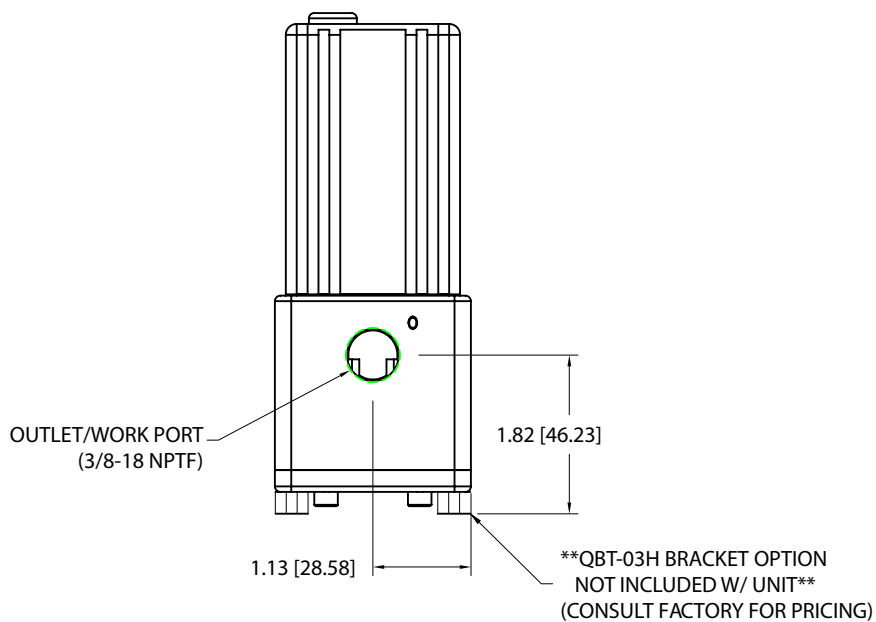
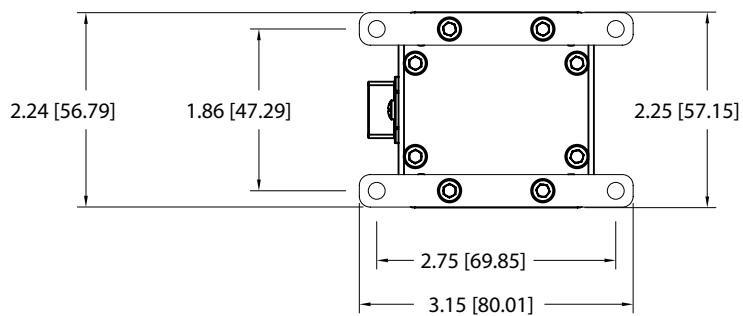
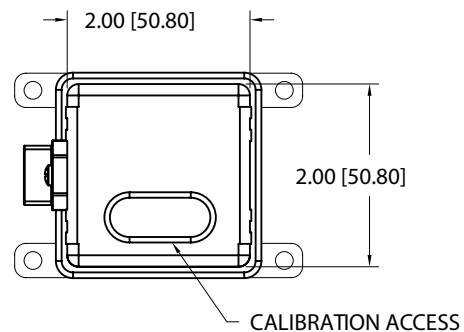

Figure 3



Notes:

1. All dimensions are inches [mm].
2. All dimensions are for reference only.

# ELECTRICAL CONNECTIONS

1. Turn off all power to valve.
2. Identify the valve's command input and analog output using the calibration card included in the package and the ordering information section on the last page of this sheet.
3. Proceed to the appropriate section corresponding to the type of valve being installed.

**NOTE: ALL COLOR CODES RELATE TO QB'S ORDERED FROM THE FACTORY WITH PRE-ASSEMBLED QBT-C-X CABLES**

## Voltage & Current Command (E, I, K, V)

All voltage command QB3H's use a differential command. If a single ended voltage will be used, tie the command return wire to DC common. Current command also uses a differential loop where the command flow is from Pin 4 to Pin 2. Some applications may require the common of the device that provides loop power for the 4-20mA command to be tied to power supply common.

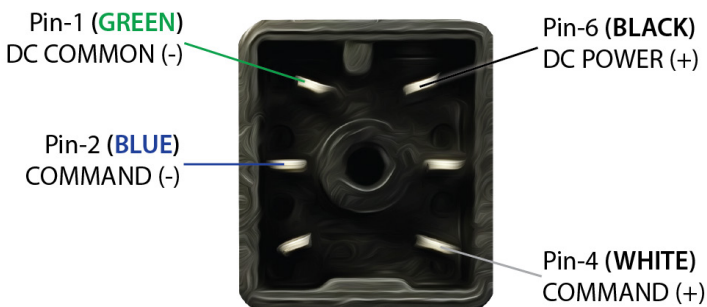

## Voltage Monitor (IE or EE)

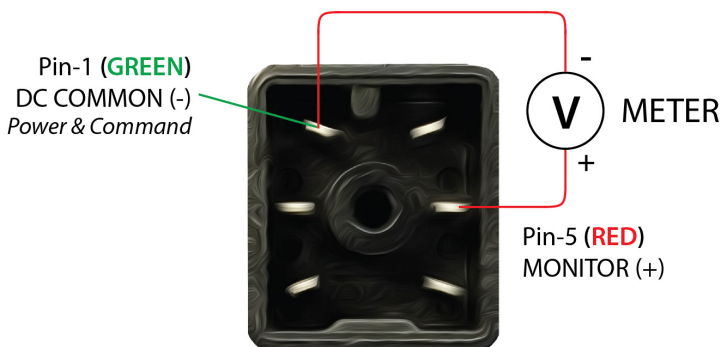

## Current Sinking Monitor (EC or IC)

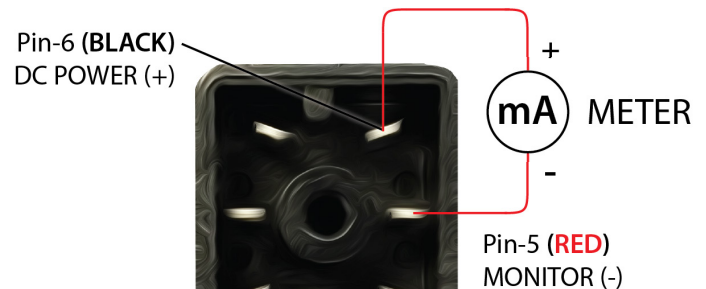

## Current Sourcing Monitor (ES or IS)

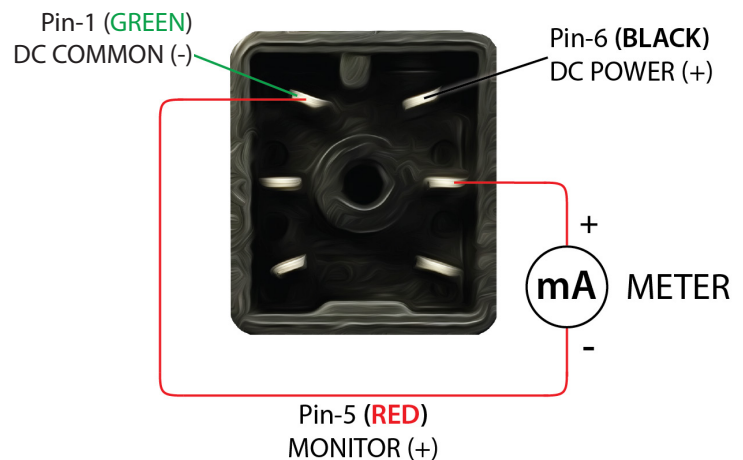

# RECALIBRATION PROCEDURE

All QB3H control valves come calibrated from the factory by trained personnel using precision calibration equipment. The QB3H valve is a closed-loop control valve using a precision internal electronic pressure sensor. Typical drift is less than 1% over the life of the product. If your QB3H valve appears to be out of calibration by more than 1%, it is not likely to be the QB3H. Check the system for plumbing leakage and/or wiring and electronic signal levels. Verify the accuracy of your measuring equipment before re-calibrating. Consult factory if you have any questions or require assistance. If the QB3H valve needs re-calibration, use the procedure described below:

1. Wire control valve according to the section titled "Electrical Connections."
2. Connect a precision measuring gauge or transducer to the outlet port of the QB3H. **NOTE: THERE MUST BE A CLOSED VOLUME OF AT LEAST 3 CU. IN BETWEEN THE VALVE OUTLET AND THE MEASURING DEVICE FOR VALVE TO BE STABLE.**
3. Plumb control valve according to section titled "Pneumatic Connections." Make sure supply pressure does not exceed the rating for the valve (see Table 1).
4. On the printed circuit board, locate the two adjustment potentiometers SPAN and ZERO. (Figure 2)
5. **ONLY USE THIS STEP IF DEVICE IS COMPLETELY OUT OF CALIBRATION. IF IT IS SLIGHTLY OUT OF CALIBRATION, PROCEED TO STEP 6.** With a small screwdriver, turn both potentiometers 15 turns clockwise. Then turn them 7 turns counter clockwise. This will put the QB3H roughly at mid scale
6. Set the electrical command input to MAXIMUM value.
7. Adjust the SPAN potentiometer until MAXIMUM desired pressure or vacuum is reached (clockwise to increase pressure).
8. Set the electrical command input to 10 percent of full value.
9. Adjust the ZERO potentiometer until 10 percent of maximum desired pressure or vacuum is reached. (Clockwise increases pressure).
10. If at any time during the calibration procedure the control valve oscillates or becomes unstable for more than one second, turn the hysteresis potentiometer clockwise until the oscillation stops, then turn it one more complete turn (same direction).
11. The ZERO and SPAN potentiometers interact slightly. Repeat steps 5-10 until no error exists.
12. Verify unit shuts off by going to zero command. Check linearity by going to at least six pressure points throughout the full range

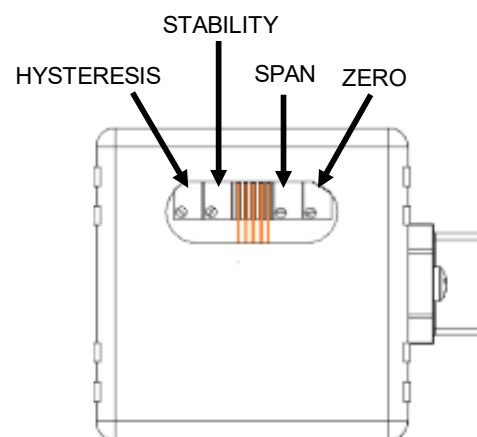
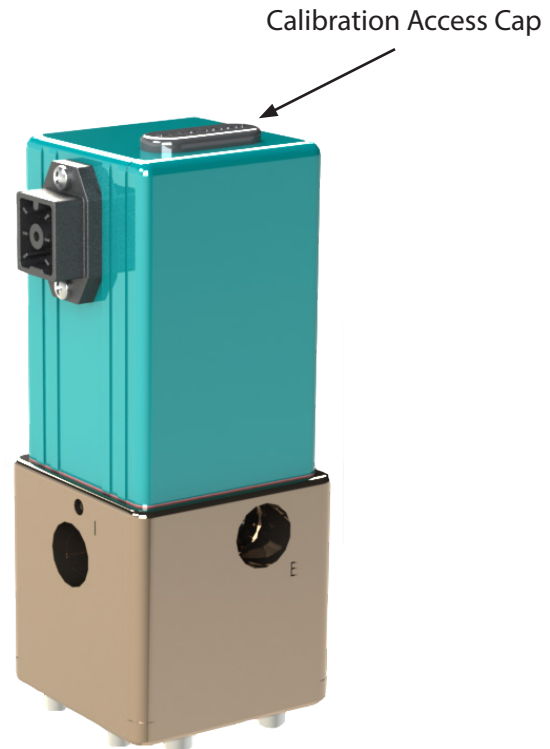

FIGURE 2

# CONFIGURATION

## QB3H

<b>ACCURACY</b>	±0.5% F.S.	<b>PRESSURE</b>	Full Vac to 500 PSIG (34 Bar)
<b>PORT SIZE</b>	3/8"	<b>MAX FLOW</b>	50 SCFM (1416 SLPM)

Example Part Number	<b>QB3H</b>	<b>A</b>	<b>N</b>	<b>E</b>	<b>E</b>	<b>Z</b>		<b>P</b>	<b>30</b>	<b>BR</b>	<b>G</b>	<b>TF</b>	<b>BR</b>	
Section Reference ->		1	2	3	4	5	6	7	8	9	10	OPTIONS		

<b>1</b>	<b>Manifold Material</b>
<b>A</b>	Nickel-Plated Aluminum
<b>B</b>	Nickel-Plated Brass

<b>2</b>	<b>Thread Type</b>
<b>N</b>	NPT

<b>3</b>	<b>Command Signal Range</b>
<b>E</b>	0 to 10 VDC
<b>I</b>	4 to 20 mADC
<b>K</b>	0 to 5 VDC
<b>V</b>	1 to 5 VDC (Requires <b>V</b> for Monitor Signal #4)

<b>4</b>	<b>Monitor Signal Range</b>
<b>X</b>	No Monitor
<b>E</b>	0 to 10 VDC
<b>K</b>	0 to 5 VDC (Requires <b>E</b> , <b>I</b> or <b>K</b> for Command Signal Range (#3))
<b>V</b>	1 to 5 VDC (Requires <b>V</b> for Command Signal Range (#3))
<b>C</b>	4 to 20 mADC (Sinking)
<b>S</b>	4 to 20 mADC (Sourcing)

<b>5</b>	<b>Zero Offset</b>
<b>N</b>	0% Pressure is Below Zero
<b>P</b>	0% Pressure is Above Zero
<b>Z</b>	0% Pressure is Zero (Typical)

<b>6</b>	<b>Zero Offset Pressure</b>
Typical is 0* - If greater than 30% of full scale pressure (#8), please consult factory.	
*If <b>Z</b> for Zero Offset, Please Leave this Section (#7) Blank	

<b>7</b>	<b>Full Scale Pressure Type</b>
<b>N</b>	100% Pressure is Below Zero
<b>P</b>	100% Pressure is Above Zero
<b>Z</b>	100% Pressure is Zero

<b>8</b>	<b>Full Scale Pressure</b>
Must be between 50 and 500 psig	

<b>9</b>	<b>Pressure Unit</b>		
<b>PS</b>	PSI	Inches Hg	<b>IH</b>
<b>MB</b>	Millibars	Inches H <sub>2</sub> O	<b>IW</b>
<b>BR</b>	Bar	Millimeters H <sub>2</sub> O	<b>MW</b>
<b>KP</b>	Kilo-pascal	Kilograms/cm <sup>2</sup>	<b>KG</b>
<b>MP</b>	Mega-pascal	Torr (Requires <b>A</b> for Unit of Measure #10)	<b>TR</b>
<b>MH</b>	Millimeters Hg	Centimeters H <sub>2</sub> O	<b>CW</b>
<b>PA</b>	Pascal		

<b>10</b>	<b>Pressure Unit of Measure</b>
<b>A</b>	Absolute Pressure
<b>G</b>	Gauge Pressure



<b>Options</b>	
<b>BR</b>	Foot-Mounted Bracket + Install
<b>O2*</b>	Oxygen Cleaned
<b>O3</b>	Oxygen Cleaned Non-O2 Use
<b>P1</b>	12-VDC Power
<b>TF†</b>	Test Under Flow

<b>Recommended Accessories</b>	
<b>QBT-C-6</b>	6 ft. Power/Command/Monitor Cable
<b>QBT-03HKIT</b>	Uninstalled Foot-Mount Bracket and Screws*
*Include BR option on part number for factory-installed foot mount bracket	

<b>Repair Kit</b>	
<b>QB3HA-REPAIRKIT</b>	QB3H - All Components

\*O2 cleaning only available on brass manifold.  
 †Only on QB3H when used with a 1:1 volume booster.  
 Many other options are available. Please consult factory for more information.

## **SAFETY PRECAUTIONS**

*Please read the following safety information before installing or operating any Proportion-Air, Inc. equipment or accessories. To confirm safety, observe 'ISO 4414: Pneumatic Fluid Power - General rules relating to systems' and other safety practices.*

### **WARNING**

Improper operation could result in serious injury or loss of life!

#### **1. PRODUCT COMPATIBILITY**

Proportion-Air, Inc. products and accessories are for use in industrial pneumatic applications with compressed air media. The compatibility of the equipment is the responsibility of the end user. Product performance and safety are the responsibility of the person who determined the compatibility of the system. Also, this person is responsible for continuously reviewing the suitability of the products specified for the system, referencing the latest catalog, installation manual, Safety Precautions and all materials related to the product.

#### **2. EMERGENCY SHUTOFF**

Proportion, Inc. products cannot be used as an emergency shutoff. A redundant safety system should be installed in the system to prevent serious injury or loss of life.

#### **3. EXPLOSIVE ATMOSPHERES**

Products and equipment should not be used where harmful, corrosive or explosive materials or gases are present. Unless certified, Proportion-Air, Inc. products cannot be used with flammable gases or in hazardous environments.

#### **4. AIR QUALITY**

Clean, dry air is not required for Proportion-Air, Inc. products. However, a 40 micron particulate filter is recommended to prevent solid contamination from entering the product.

#### **5. TEMPERATURE**

Products should be used with a media and ambient environment inside of the specified temperature range of 32°F to 158°F. Consult factory for expanded temperature ranges.

#### **6. OPERATION**

Only trained and certified personnel should operate electronic and pneumatic machinery and equipment. Electronics and pneumatics are very dangerous when handled incorrectly. All industry standard safety guidelines should be observed.

#### **7. SERVICE AND MAINTENANCE**

Service and maintenance of machinery and equipment should only be handled by trained and experienced operators. Inspection should only be performed after safety has been confirmed. Ensure all supply pressure has been exhausted and residual energy (compressed gas, springs, gravity, etc.) has been released in the entire system prior to removing equipment for service or maintenance.

### **CAUTION**

Improper operation could result in serious injury to people or damage to equipment!

#### **1. PNEUMATIC CONNECTION**

All pipes, pneumatic hose and tubing should be free of all contamination, debris and chips prior to installation. Flush pipes with compressed air to remove any loose particles.

#### **2. THREAD SEALANT**

To prevent product contamination, thread tape is not recommended. Instead, a non-migrating thread sealant is recommended for installation. Apply sealant a couple threads from the end of the pipe thread to prevent contamination.

#### **3. ELECTRICAL CONNECTION**

To prevent electronic damage, all electrical specifications should be reviewed and all electrical connections should be verified prior to operation.

### **EXEMPTION FROM LIABILITY**

**1. Proportion-Air, Inc.** is exempted from any damages resulting from any operations not contained within the catalogs and/or instruction manuals and operations outside the range of its product specifications.

**2. Proportion-Air, Inc.** is exempted from any damage or loss whatsoever caused by malfunctions of its products when combined with other devices or software.

**3. Proportion-Air, Inc.** and its employees shall be exempted from any damage or loss resulting from earthquakes, fire, third person actions, accidents, intentional or unintentional operator error, product misapplication or irregular operating conditions.

**4. Proportion-Air, Inc.** and its employees shall be exempted from any damage or loss, either direct or indirect, including consequential damage or loss, claims, proceedings, demands, costs, expenses, judgments, awards, loss of profits or loss of chance and any other liability whatsoever including legal expenses and costs, which may be suffered or incurred, whether in tort (including negligence), contract, breach of statutory duty, equity or otherwise.

### **WARRANTY**

Proportion-Air, Inc. products are warranted to the original purchaser only against defects in material or workmanship for eighteen (18) months from the date of manufacture. The extent of Proportion-Air's liability under this warranty is limited to repair or replacement of the defective unit at Proportion-Air's option. Proportion-Air shall have no liability under this warranty where improper installation or filtration occurred.

# **PROPORTION**

ProportionAir.com

8250 N 600 W

P.O. Box 218

McCordsville, IN 46055

*info@proportionair.com*

Handcrafted in the USA  
ISO 9001-2015 Certified