



QB1T/QB2T

INSTALLATION & MAINTENANCE INSTRUCTIONS

DESCRIPTION / IDENTIFICATION

The QB series valve uses Proportion- Air closed loop technology for Pressure control. It gives an output pressure proportional to an electrical command signal input.

The QB1 is a complete closed loop servo system consisting of valves, manifold, housing and electronic controls. Pressure is controlled by the use of two solenoid valves. One valve functions as inlet control, the other as exhaust. The pressure output is measured by a pressure transducer internal to the QB1 and provides a feedback signal to the electronic controls. This feedback signal is compared with the command signal input. A difference between the two signals causes one of the solenoid valves to open, allowing flow in or out of the system. Accurate pressure is maintained by controlling these two valves.

The QB2 is similar to the QB1 but uses a double loop control scheme. In addition to the internal pressure transducer, the QB2 receives an electrical signal from an external sensing device. This primary feedback signal is compared against the command signal input. This comparison is then summed with the internal pressure transducer signal. The gain of the circuit is such that priority is given to the external feedback signal. A difference between the command signal and the feedback signal causes one of the solenoid valves to be activated.

A monitor output is provided for the system measurement. All QB valves come standard with an analog voltage monitor output.

QB1 monitor output is an amplified signal from the internal pressure transducer. QB2 monitor output is a buffered signal from the primary external transducer connected to the QB2. For QB valves with model number TFEE or TFIE the monitor output is voltage. The monitor output is analog current, if the valve model number is TFEC or TFIC. See ordering information for further details.

INSTALLATION

1. Apply a small amount of anaerobic sealant (provided) to the male threads of the in-line filter supplied with valve.

CAUTION: USE ONLY THE THREAD SEALANT PROVIDED. OTHER SEALANTS SUCH AS PTFE TAPE AND PIPE DOPE CAN MIGRATE INTO THE FLUID SYSTEM CAUSING FAILURES.

2. Install the in-line filter into the port labeled IN on QB valve.
3. Connect supply line to the in-line filter port. Connect device being controlled to port labeled OUT on QB valve.
4. Mount valve accordingly.
5. The valve can be mounted in any position without affecting performance. Mounting bracket QBT-01 (ordered separately) can be used to attach valve to a panel or wall surface.
6. Proceed with electrical connections.

SPECIFICATIONS

ELECTRICAL

SUPPLY VOLTAGE.....	15-24 VDC
SUPPLY CURRENT.....	250mA req'd.
COMMAND SIGNAL	
VOLTAGE.....	0-10 VDC
CURRENT.....	4-20mA
COMMAND SIGNAL IMPEDANCE	
VOLTAGE.....	4.75 KΩ
CURRENT.....	100 Ω
ANALOG MONITOR SIGNAL	
VOLTAGE.....	0-10 VDC @ 20mA max
CURRENT.....	4-20mA sinking (sourcing opt.)

MECHANICAL

PRESSURE RANGES.....	29.9 in. Hg (vac) - 500 psig (760 mmHg (vac) - 34.47 BAR)
OUTPUT PRESSURE†.....	0-100% of range
FLOW RATE.....	1.2 SCFM max @ 100 psig inlet (34L/min @ 6.89 BAR)
Cv CAPACITY.....	0.04
MIN. CLOSED END VOLUME.....	1 in ³
FILTRATION RECOMMENDED.....	20 micron nominal (included)
LINEARITY/HYSTERESIS.....	<±0.15% F.S. BFLS
REPEATABILITY.....	<±0.02% F.S.
ACCURACY.....	<±0.2% F.S.
WETTED PARTS‡.....	Elastomers - Fluorocarbon Manifold - Brass Valves - Nickel plate brass P. Transducer - Silicon, Aluminum

PHYSICAL

OPERATING TEMPERATURE.....	32-158°F [0-70°C]
WEIGHT.....	1.02 lb [0.50 Kg]
PROTECTION RATING.....	NEMA 4
HOUSING.....	Aluminum
FINISH.....	Black Anodized

† Pressure ranges are customer specified. Output pressures other than 100% are available.

‡ Others available

TABLE 1

RATED INLET PRESSURE FOR STANDARD QB VALVES

For valves ordered with MAX. calibrated pressure of:	Max. inlet pressure is:
Vacuum up to 10 psig (0.69 bar)	Consult factory
10.1 up to 30 psig (0.70 up to 2 bar)	35 psig (2.4 bar)
31 up to 100 psig (2.1 up to 7 bar)	110 psig (7.6 bar)
101 up to 175 psig (7 up to 12 bar)	190 psig (13 bar)
176 up to 300 psig (12.1 up to 20.7 bar)	330 psig (22.8 bar)
301 up to 500 psig (20.8 to 34.5 bar)	550 psig (37.9 bar)

NOTE: Valves with options S67, S91, or S106 can handle higher inlet pressures. Inlet pressure are not the same for valves mounted to volume boosters. Consult factory for further information.

RE-CALIBRATION PROCEDURE

All QB control valves come calibrated from the factory by trained personnel using precision calibration equipment. The QB valve is a closed loop control valve using a precision electronic pressure sensor. Typical drift is less than 1% over the life of the product. If your QB valve appears to be out of calibration by more than 1%, it is not likely to be QB. Check the system for plumbing leakage, wiring and electronic signal levels. Verify the accuracy of your measuring equipment before re-calibrating. Consult factory if you have any questions or require assistance. If the QB valve needs re-calibration, use the procedure described below:

QB1 VALVES

- Identify the inputs and outputs of the valve using the model number of the valve, calibration card included with the valve, and the information provided in this sheet.
 - Connect a precision measuring gage or pressure transducer to the OUT port of the QB.
- NOTE: THERE MUST BE A CLOSED VOLUME OF AT LEAST 1 CU. IN. (17 CC) BETWEEN THE VALVE OUTLET AND THE MEASURING DEVICE FOR THE VALVE TO BE STABLE.**
- Connect the correct supply source to the IN port of the QB, making sure the pressure does not exceed the rating for the valve (See Table 1).
 - Locate the plastic calibration access cap on top of the QB valve and completely remove it. Located underneath are two adjustment trimpots, Zero "Z" and Span "S". See figure 1 for pots location.
 - NOTE: Only use this step if your device is totally out of calibration. If it is slightly out of calibration, omit this step and move on to paragraph 6. Using a small screwdriver, turn both trimpots 15 turns clockwise. Then turn both trimpots 7 turns counterclockwise. This will put the QB roughly at mid-scale.
 - Make correct electrical connections as noted. Make sure there is a proper meter in place to measure the command input to the QB.
 - Set the electrical command input to MAXIMUM value.
 - Adjust the SPAN pot until MAXIMUM desired pressure is reached (clockwise *increases* pressure).
 - Set the electrical command input to MINIMUM value.
 - Adjust the ZERO pot until MINIMUM desired pressure is reached (clockwise *increases* pressure).
 - Repeat ZERO and SPAN adjustments, which interact slightly, until QB1 valve is calibrated back to proper range. Step 6 - 9.
 - Replace calibration access cap.

QB2 VALVES

This section assumes there is a properly scaled and calibrated transducer for use as 2nd loop feedback signal. For information on re-calibrating Proportion-Air DS series pressure transducers see sheet BR060.

- Follow, in order, steps 1-5 as noted in the section titled QB1 VALVES.
- Make correct electrical connections as noted. Make sure there is a proper meter in place to measure the command input to the QB2. Make sure the 2nd loop signal is connected.
- Set the electrical command input to MAXIMUM value.
- Adjust the SPAN pot until MAXIMUM desired pressure is reached (clockwise *increases* pressure).
- Set the electrical command input to MINIMUM value.
- Adjust the ZERO pot until MINIMUM desired pressure is reached (clockwise *increases* pressure).
- Repeat ZERO and SPAN adjustments, which interact slightly, until QB2 valve is calibrated back to proper range. Steps 3 - 6.
- Replace calibration access cap.

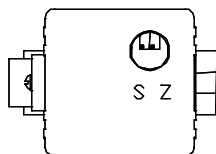

Figure 1

ELECTRICAL CONNECTIONS

- Turn off all power to valve.
- Identify the valve's command input and analog output using the calibration card included in the package and the ordering information section on the last page of this sheet.
- Proceed to the appropriate section corresponding to the type of valve being installed.

NOTE: ALL COLOR CODES RELATE TO QB'S ORDERED FROM THE FACTORY WITH WIRE LEADS.

Voltage command valves

All voltage command QB's use common mode voltage, meaning the DC Common pin (Pin 1) is the common reference for both power and command. Pin 1 is used as both the command signal common and power supply common. The following diagram shows the proper connections.

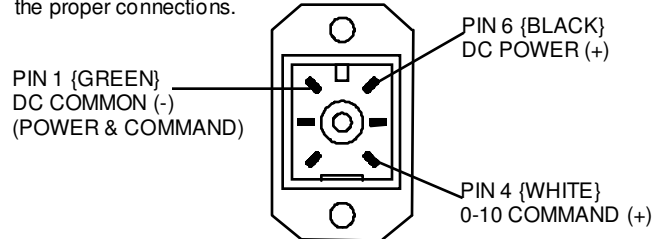

Current command valves

All current command QB's use a differential current loop scheme (not isolated), meaning current flow is from Pin 4 to Pin 2 on the QB valve. Some applications may require the common of the power supply that provides loop power for the 4-20mA command to be tied to power supply common. The following diagram shows the correct connection for conventional current flow.

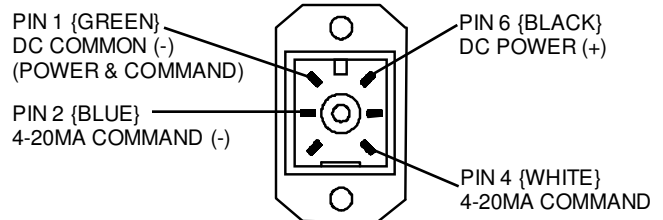

Voltage monitor (TFEE or TFIE)

Use the following wiring diagram for QB valves with a voltage monitor output.

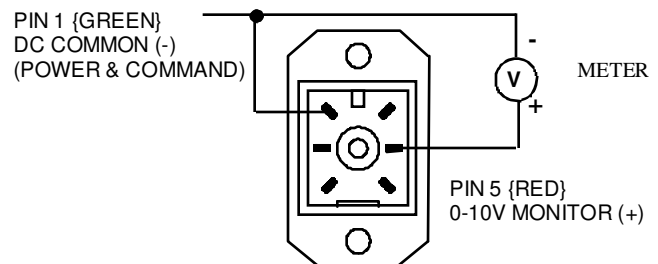

Current monitor (TFEC or TFIC)

Use the following wiring diagram for QB valves with a current sinking monitor output.

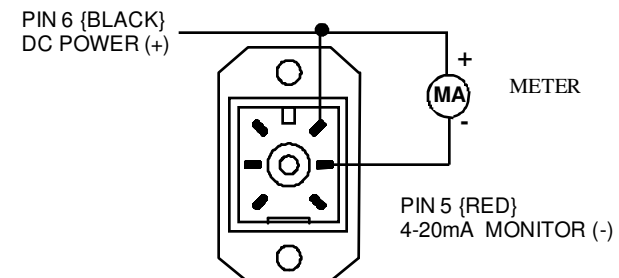

Current Sourcing Monitor (TFES or TFIS)

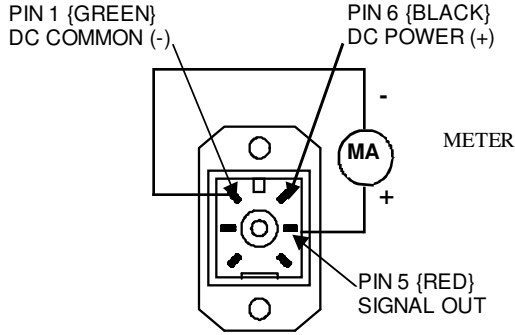

QB2-S305 option valves

Second loop signal is plugged into auxiliary receptacle on opposite side.

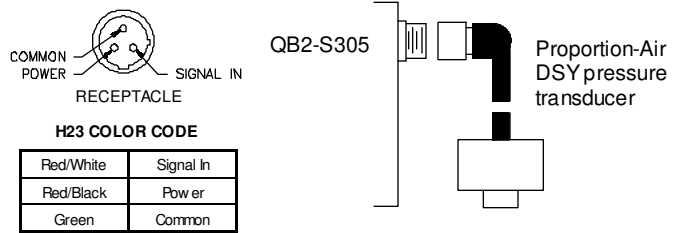

QB2 SECOND LOOP CONNECTIONS

All QB2 valves are designed to accept a 0-10 volt second loop input signal, unless ordered with special option code S230 (4-20 mA second loop input). Reference the following wiring diagrams for details.

Standard QB2 valves

Second loop signal is wired into the main electrical connector.

QB2-S230 option valves

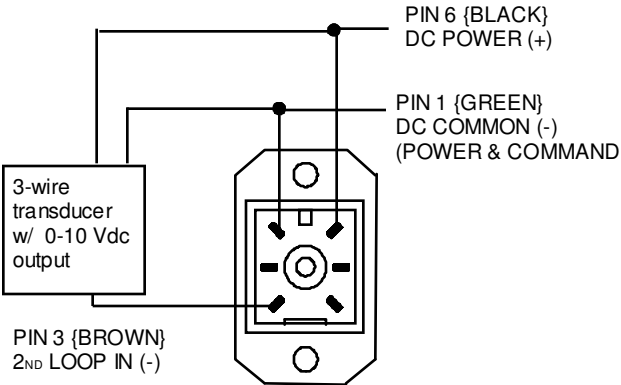
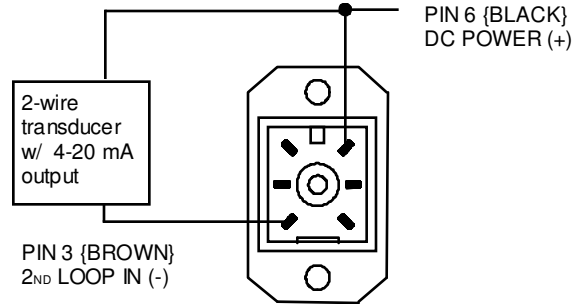

DIMENSIONS in [mm]

MOUNTING BRACKET

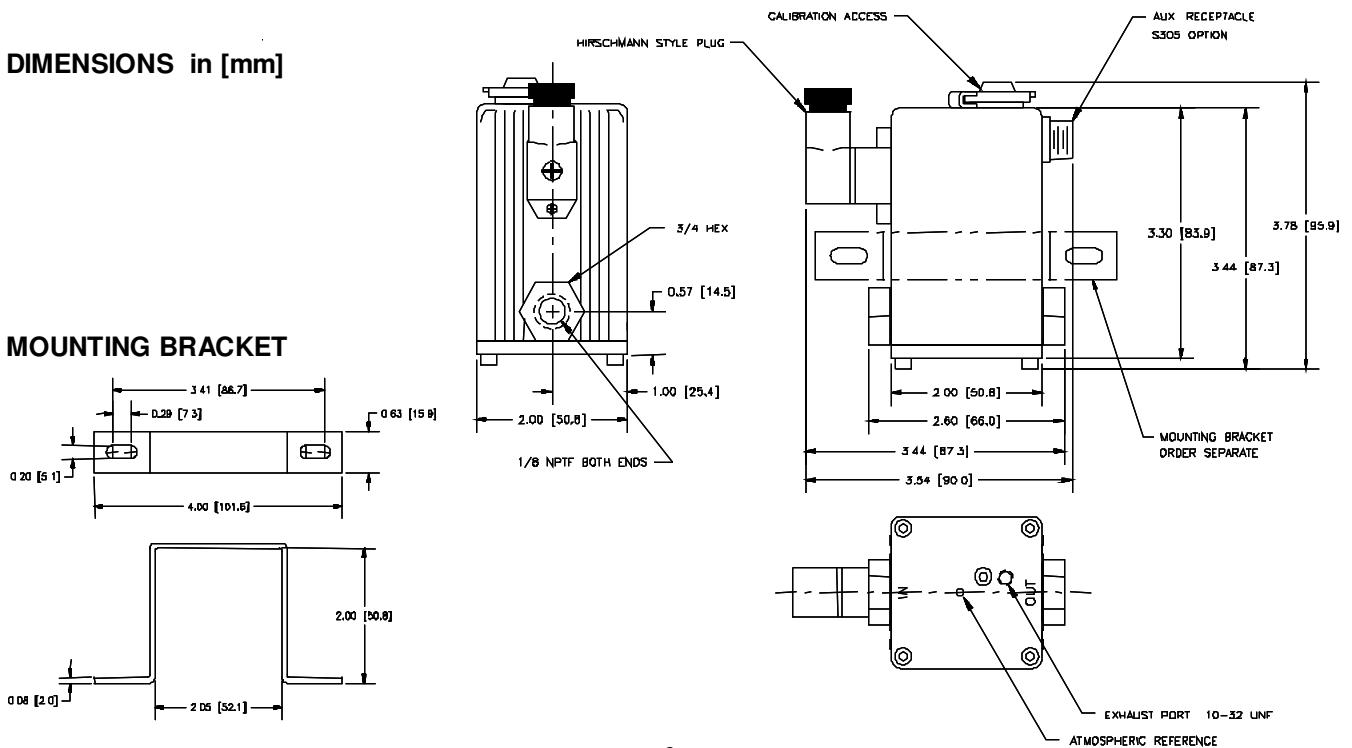

PARTS LIST

- 1. Housing
- 2. Valve (2)
- 3. Manifold
- 4. O-ring (2)
- 5. Electronic board
- 6. Sensor
- 7. Gasket
- 8. Filter/Breather
- 9. Lid
- 10. Screw (5)
- 11. Connector (2)
- 12. O-ring (2)
- 13. O-ring (2)
- 14. Fitting (2)
- 15. Connector
- 16. Screw (2)
- 17. Connector assembly
- 18. Receptacle assembly
- 19. Wire harness
- 20. Cap
- 21. O-ring

PART NUMBERS FOR REPLACEMENT ITEMS*

- 2. Consult factory
- 4. H134
- 6. Consult factory
- 7. H1054
- 10. H1049
- 12. H2014
- 13. H011
- 14. H1048
- 17. H615
- 20. H368
- 21. H040

QB EXPLODED VIEW

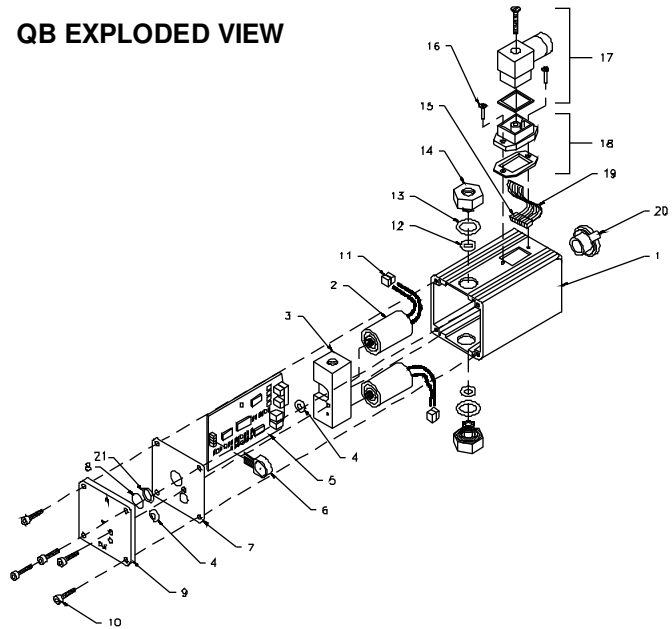

* Include complete QB part number & any modification numbers when ordering replacement parts

ORDERING INFORMATION

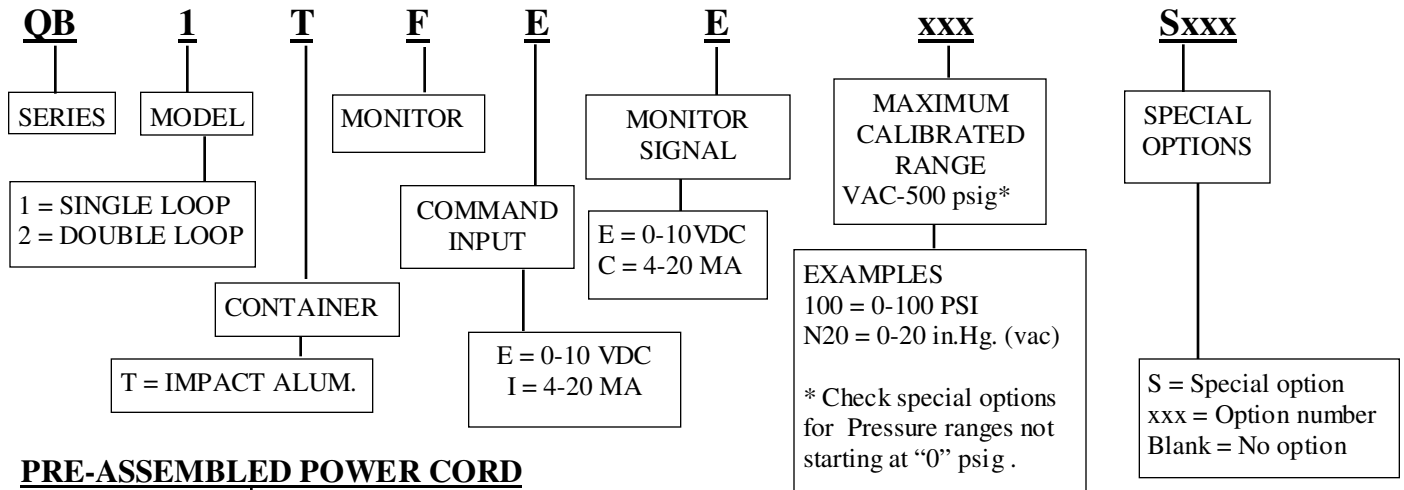

PRE-ASSEMBLED POWER CORD

QBT-C-6

Length in feet (Other length are available from 1 to 25 feet)

MOUNTING BRACKET

QBT-01

Proportion-Air products are warranted to the original purchaser only against defects in material or workmanship for one (1) year from the date of manufacture. The extent of Proportion-Air's liability under this warranty is limited to repair or replacement of the defective unit at Proportion-Air's option. Proportion-Air shall have no liability under this warranty where improper installation or filtration occurred.

All specifications are subject to change without notice. **THIS WARRANTY IS GIVEN IN LIEU OF, AND BUYER HEREBY EXPRESSLY WAIVES, WARRANTIES OR LIABILITIES, EXPRESSED, IMPLIED OR STATUTORY, INCLUDING WITHOUT LIMITATION ANY OBLIGATION OF PROPORTION-AIR WITH REGARD TO CONSEQUENTIAL DAMAGES, WARRANTIES OF MERCHANTABILITY, DESCRIPTION, AND FITNESS FOR A PARTICULAR PURPOSE.**

WARNING: Installation and use of this product should be under the supervision and control of properly qualified personnel in order to avoid the risk of injury or death.

PROPORTION-AIR, INC. BOX 218 MCCORDSVILLE, IN USA 46055

PHONE: (317)335-2602 FAX: (317)335-3853

web site: www.proportionair.com

email address: info@proportionair.com