



PRESSURE



FLOW



FORCE



TENSION



POSITION



TORQUE



VACUUM

PROPORTIONAIR

THE FUTURE OF CONTROL™

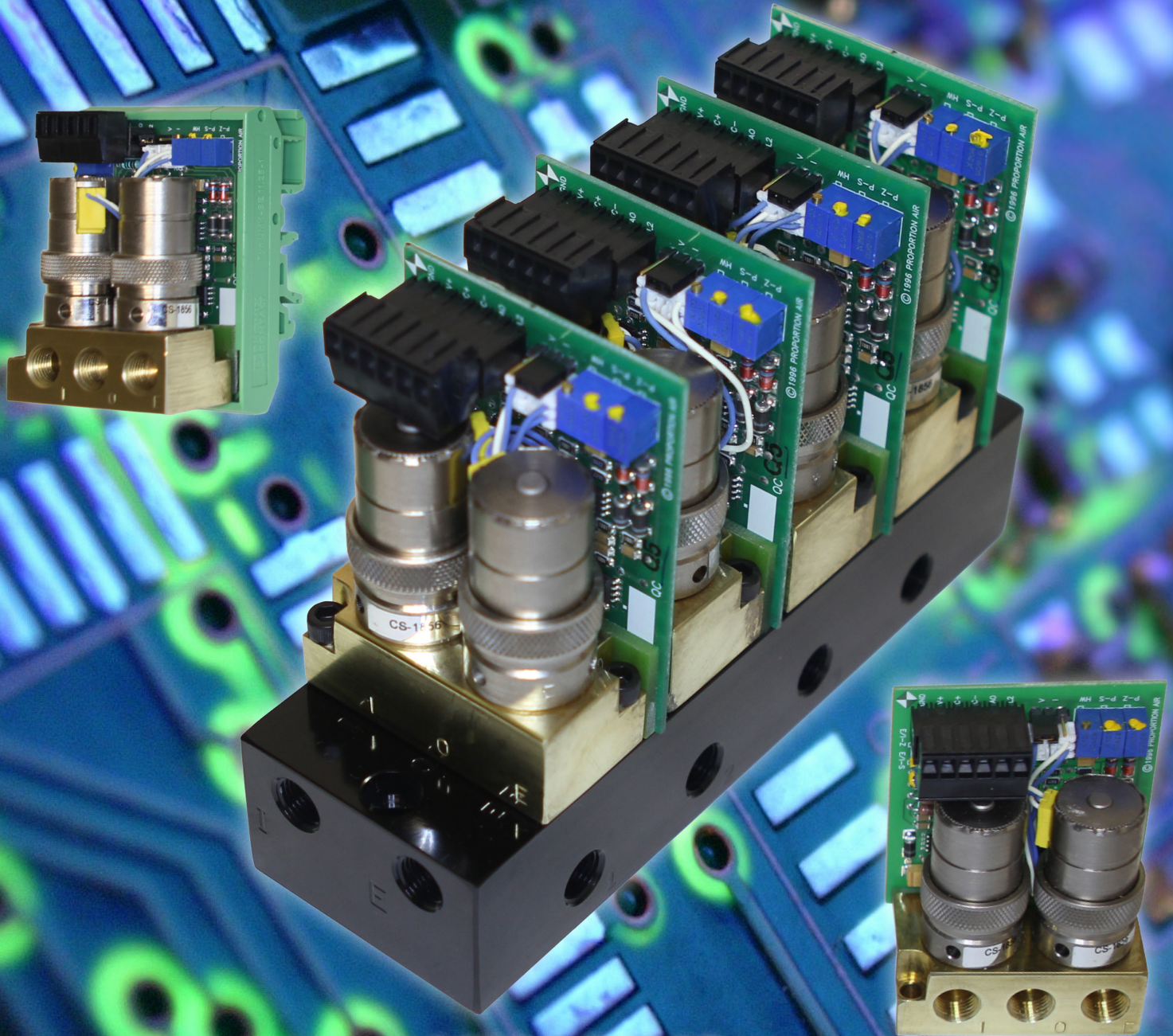

MM1/MM2

CONTROL VALVES

CLOSED LOOP PROPORTIONAL PRESSURE CONTROLS

317-335-2602

P.O. Box 218 McCordsville, Indiana 46055

www.proportionair.com

FEATURES

- Universal Mounting Din Rail, Panel Mount, or Sub-base Manifold Mount
- Small and compact
- Fast and accurate
- Mounts in any position
- Unaffected by supply pressure changes
- Non-air consuming in steady state

BENEFITS

- Takes up less space
- Reduces plumbing
- Simplifies design
- Easy tuning of system stability

APPLICATIONS

- Manufacturing and Automation
- Instrumentation
- Medical
- Process Control
- Robotics
- Test and Measurement
- Common supply port on sub-base manifold
- Field serviceable
- Jumper selectable command 0-10 VDC, 4-20 mA
- Adjustable hysteresis band
- Interfaces with a variety of controller outputs
- 0-10 VDC and 4-20 mA analog output

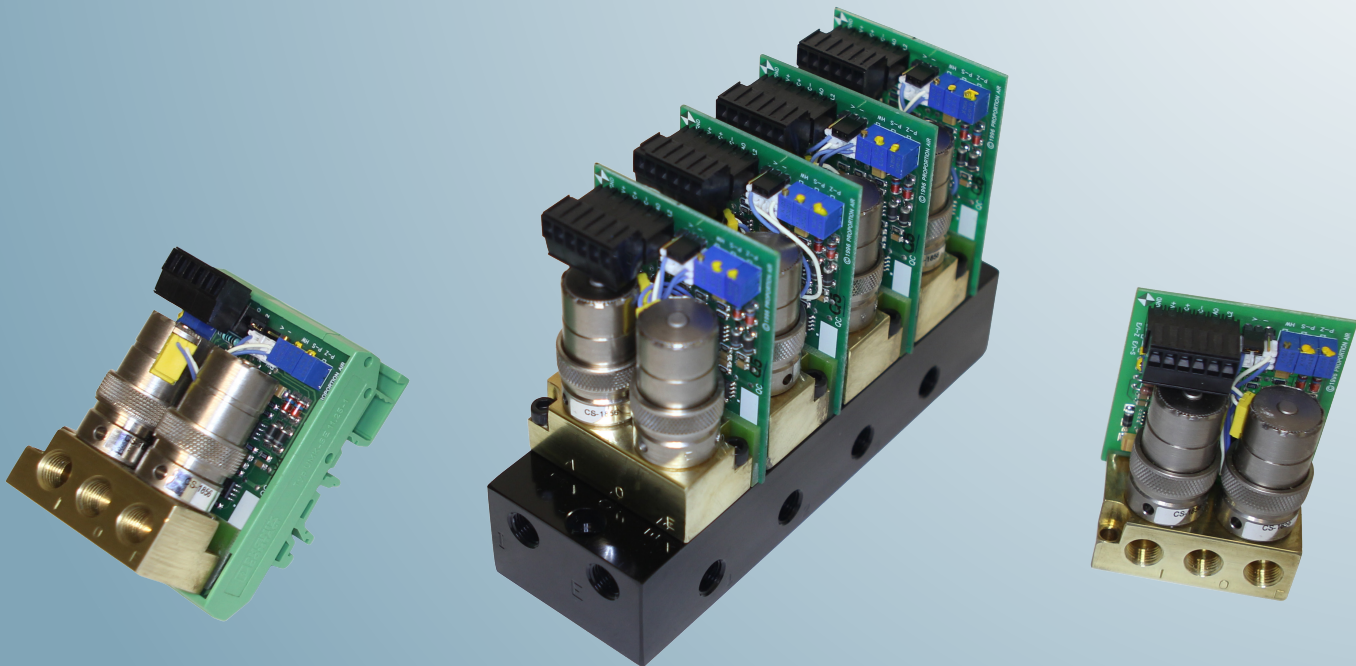

PERFORMANCE CHARACTERISTICS

LINEARITY

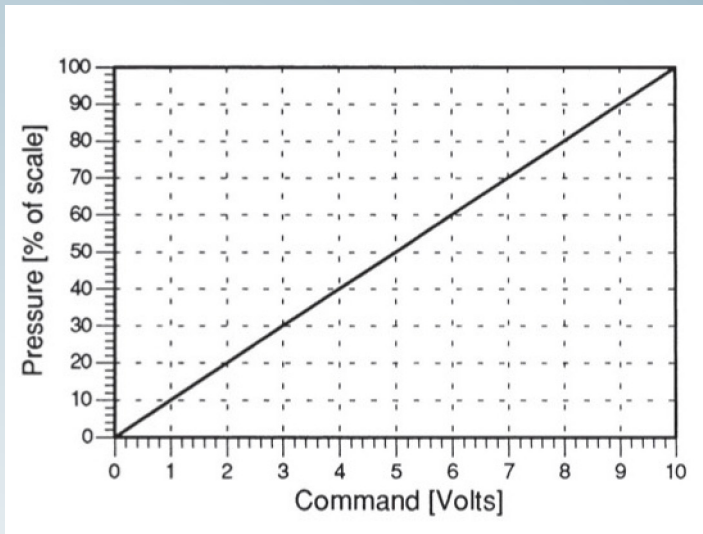

Fig. 1 This chart shows linear characteristics of MM products when given a ramp signal from 0-10 volts. Characteristics would be similar for 4-20 mA units.

RESPONSE TO STEP INPUT

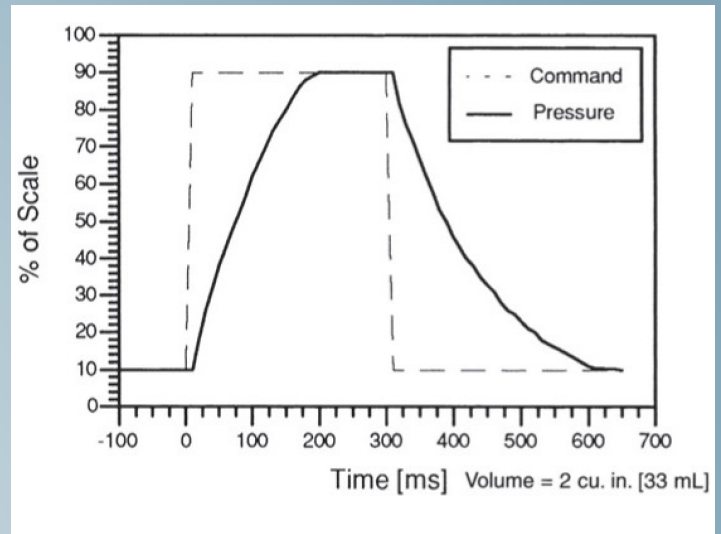

Fig. 2 Times for MM to fill/exhaust a closed chamber. Step command signal is superimposed over pressure trace. Time is determined by difference between command signal and pressure achieved.

FUNCTIONAL DESCRIPTION

The MM series proportional control valves utilize Proportion-Air's unique closed loop control technology for superior control of pressurized gases and fluids. The MM is designed to have "Universal Mounting" capabilities which include Din Rail, panel mount, or manifold mounting for use on sub-base for multiple unit applications. Sub-base configurations are available from 2-12 units. The sub-base offers a common supply and exhaust port with individual controlled outlet ports to minimize plumbing connections.

The MM series units can be built as single closed loop or dual closed loop (cascading loop) control valves. The MM1 and MM2 deliver pressure control which is linearly proportional to either a DC current or DC voltage command input.

The MM1 uses two solenoid valves to control system pressure. One valve functions as an inlet control, the other as an exhaust control. A strain gauge pressure transducer measures the system pressure and provides a feedback signal to the electronic controls. This feedback signal is compared against the command signal. Any difference between the two signals causes one

of the solenoid valves to open allowing pressure in or out of the system. Closed loop proportional control of pressure is maintained in this manner.

The MM2 is similar to the MM1 but uses a double loop control scheme. In addition to the internal pressure transducer, the MM2 also receives a feedback signal (0-10 Vdc Standard) from an external sensing device.

The external signal functions as the primary feedback and is compared to the command signal. This comparison is summed with the internal pressure transducer signal. A difference between the two comparisons causes one of the two solenoid valves to open allowing flow in or out of the system.

Since the secondary feedback is an electrical signal, many types of sensors may be used as a feedback such as force, position, pressure, vacuum, etc. An analog output is also standard on both the MM1 and MM2 to be used for data acquisition or to a panel meter for display.

The analog monitor signal is taken from the internal pressure sensor on MM1's and from the secondary feedback on the MM2.

DIMENSIONS

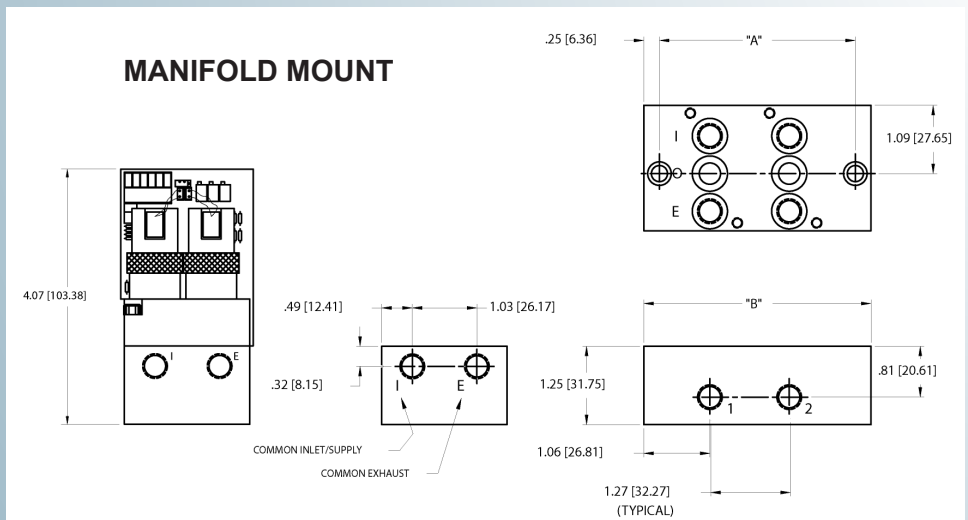
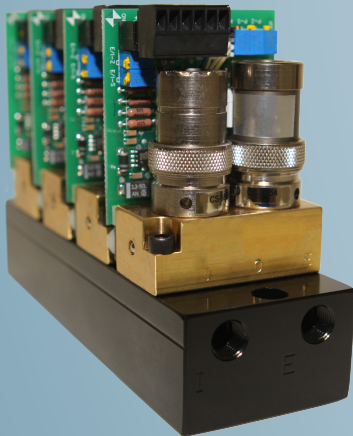
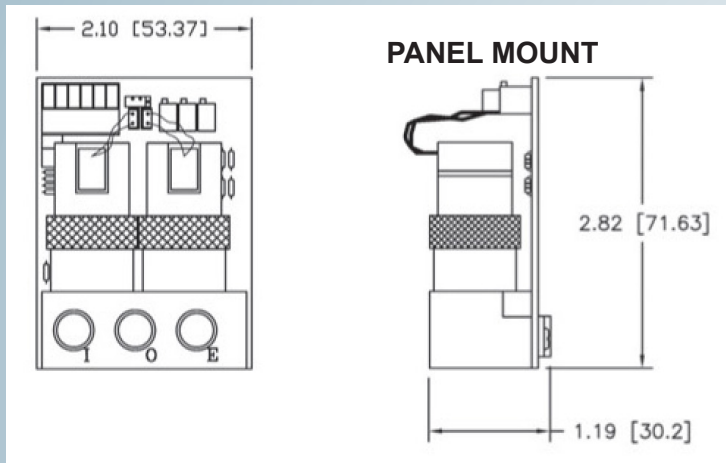
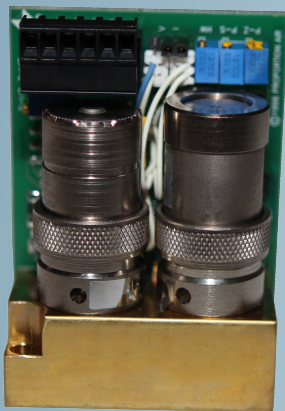
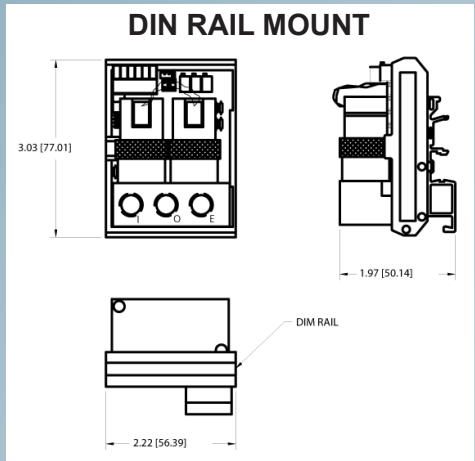
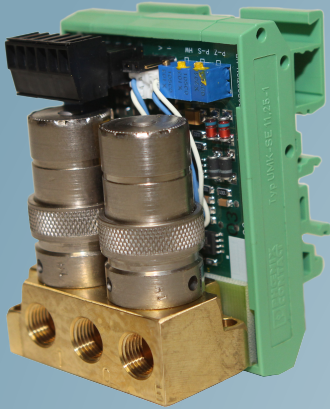

NOTES:
 Dimensions are inches (mm)
 Dimensions are for reference use
 All ports are 1/8-27 NPTF

DIMENSIONS		
STATIONS	DIM "A"	DIM "B"
2	3.13(79.40)	3.63(92.13)
3	4.39(111.50)	4.89(124.21)
4	5.66(143.76)	6.16(156.46)
5	6.92(175.72)	7.43(188.72)
6	8.19(208.03)	8.69(220.73)
7	9.46(252.99)	9.95(252.98)
8	10.72(272.29)	11.22(284.99)
9	11.99(304.55)	12.49(317.25)
10	13.25(336.55)	13.76(349.50)
11-UP	CONSULT FACTORY	

GENERAL SPECIFICATIONS

ELECTRICAL

Supply Voltage 15-24 VDC
Supply Current 250 mA max (per unit)
Command Signal
 Voltage 0-10 VDC
 Current 4-20 mA differential
2nd Loop Input 0-10 VDC
Monitor Signal 0-10 4-20mA
Command Signal Impedance
 Voltage 4700 Ω
 Current 100 Ω
2nd Loop Signal Impedance 4700 n
Monitor Signal 0-10 VDC @ 10 mA

PHYSICAL

Operating Temp 32-158°F [0-70°C]
Weight 7 lb [.3 kg]*

*Weight is per unit not including sub-base manifold.

MECHANICAL

Pressure Ranges 29.9 in. Hg (VAC) - 175 psig (12 barg)**
[760 mm Hg (VAC) -1207 kPa]
Output Pressure 0-100% of range
Flow Rate
 Standard 1.2 SCFM @ 100 psig (6.9 barg) inlet
 (34Lmin @ 689.5 kPa)
 High Flow (S938) 3.5 SCFM @ 100 psig (6.9 barg)
 inlet [99Lmin@689.5 KPa]
Cv Capacity
 Standard 0.04
 High Flow (S938) 0.13
Min. Closed End Volume 1 in³
Filtration Recommended 40 micron minimal
Linearity Hysteresis +/- 0.2% F.S. BFSL (Adjustable)
Repeatability +/- 0.02 F.S. 0-0.4% F.S.
Accuracy +/- 0.2% F.S.
Temperature Effect +/- 25°C = +/- 0.7% FS
Wetted Parts Elastomers - Fluorocarbon; Manifold - Brass***
Valves - Polyamide, Alumina Ceramic, Epoxy, Silicon, Glass and Solder
Port Sizes 1/8 inch
**Pressure ranges are customer specified.
***Other manifold materials are available. Consult Factory.

TYPICAL SUB-BASE APPLICATION

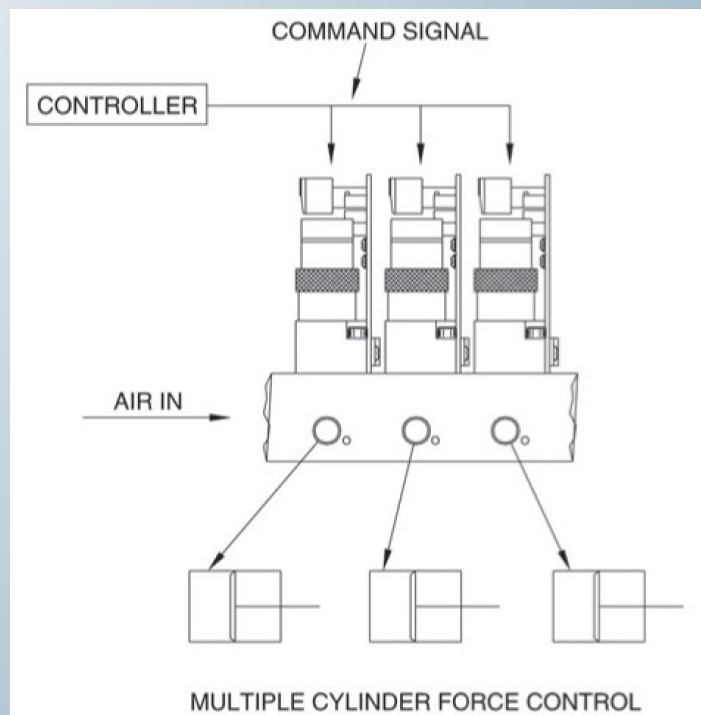

MM SERIES ORDERING INFORMATION

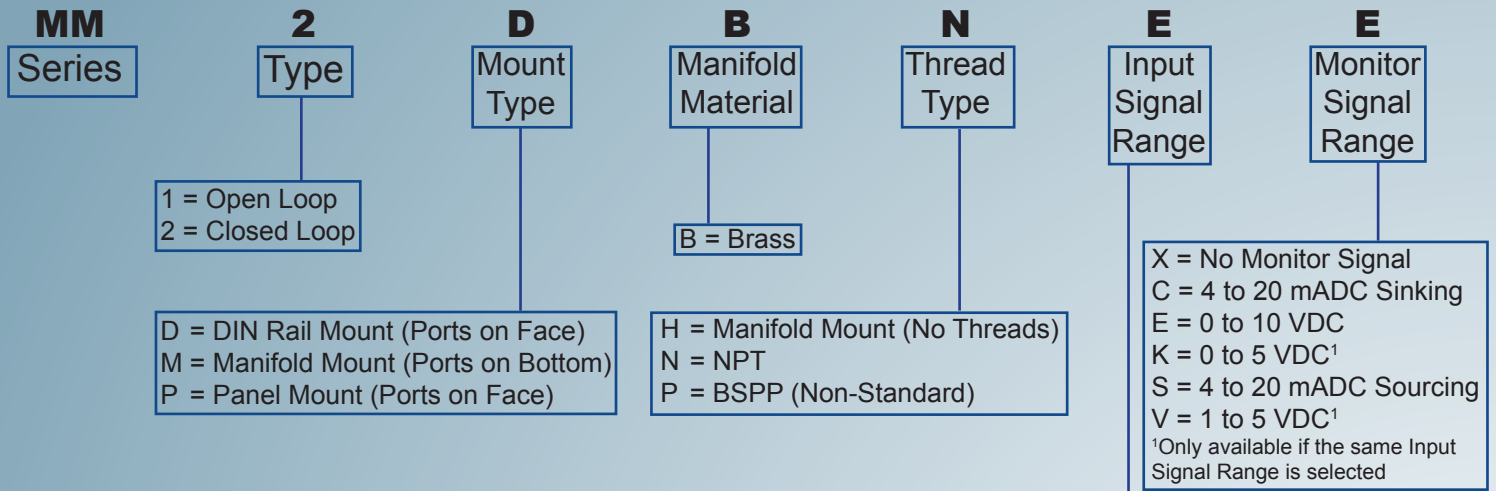

Max IN Pressure: 300 psig (20.6 barg)
 Max OUT Pressure: 175 psig (12 barg)
 Typical Accuracy: +/- 0.2% (Full Scale of sensor)
 Regulators: none
 Power Supply: 15 vdc, 24 vdc, 12 vdc (Option P1)

E= 0 to 10 VDC
 I = 4 to 20 mADC
 K= 0 to 5 VDC
 V= 1 to 5 VDC

MM SERIES ACCESSORIES

Power Connector

H14612

Mounting Kits

DIN Rail	DRMKT-01
Panel Mount	PMK-MM
Manifold Mount	See HARDWARE KIT

Station Plug

H316

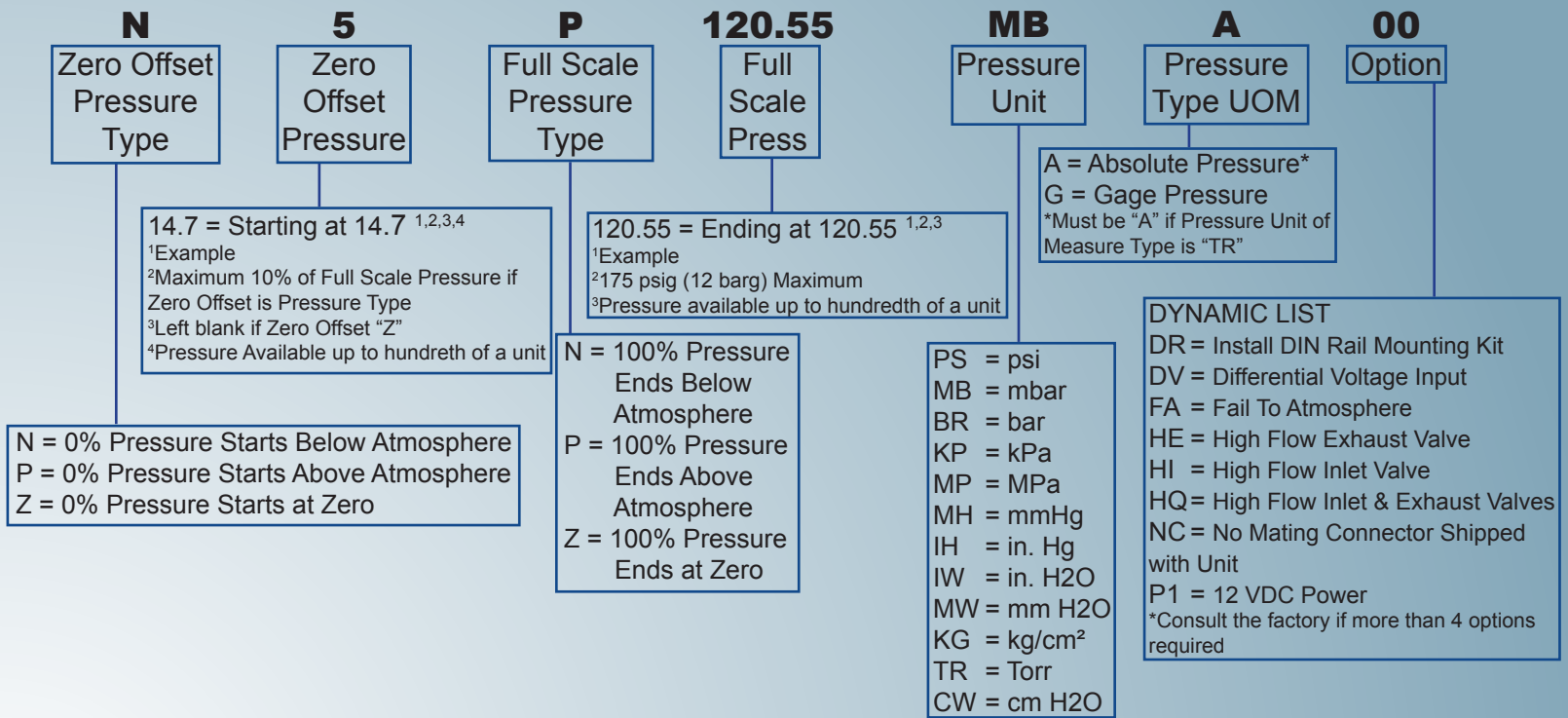

MM SERIES SUB BASE MANIFOLD

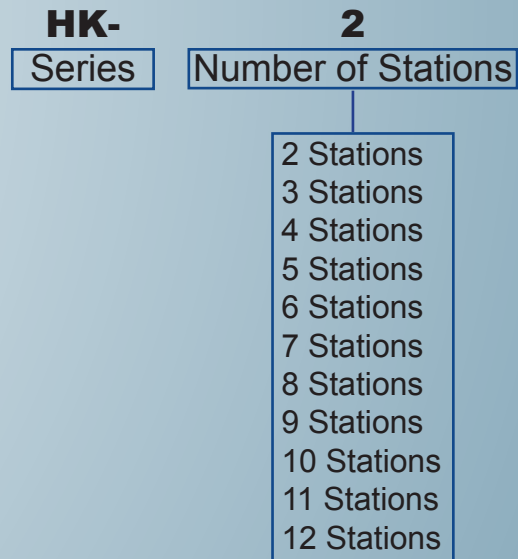
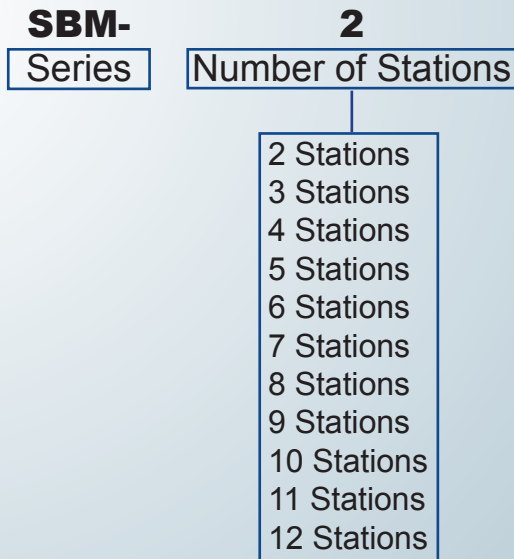

Proportion-Air offer you the technical knowledge, expertise and capabilities that have developed concepts into the foremost control products in operation around the world.

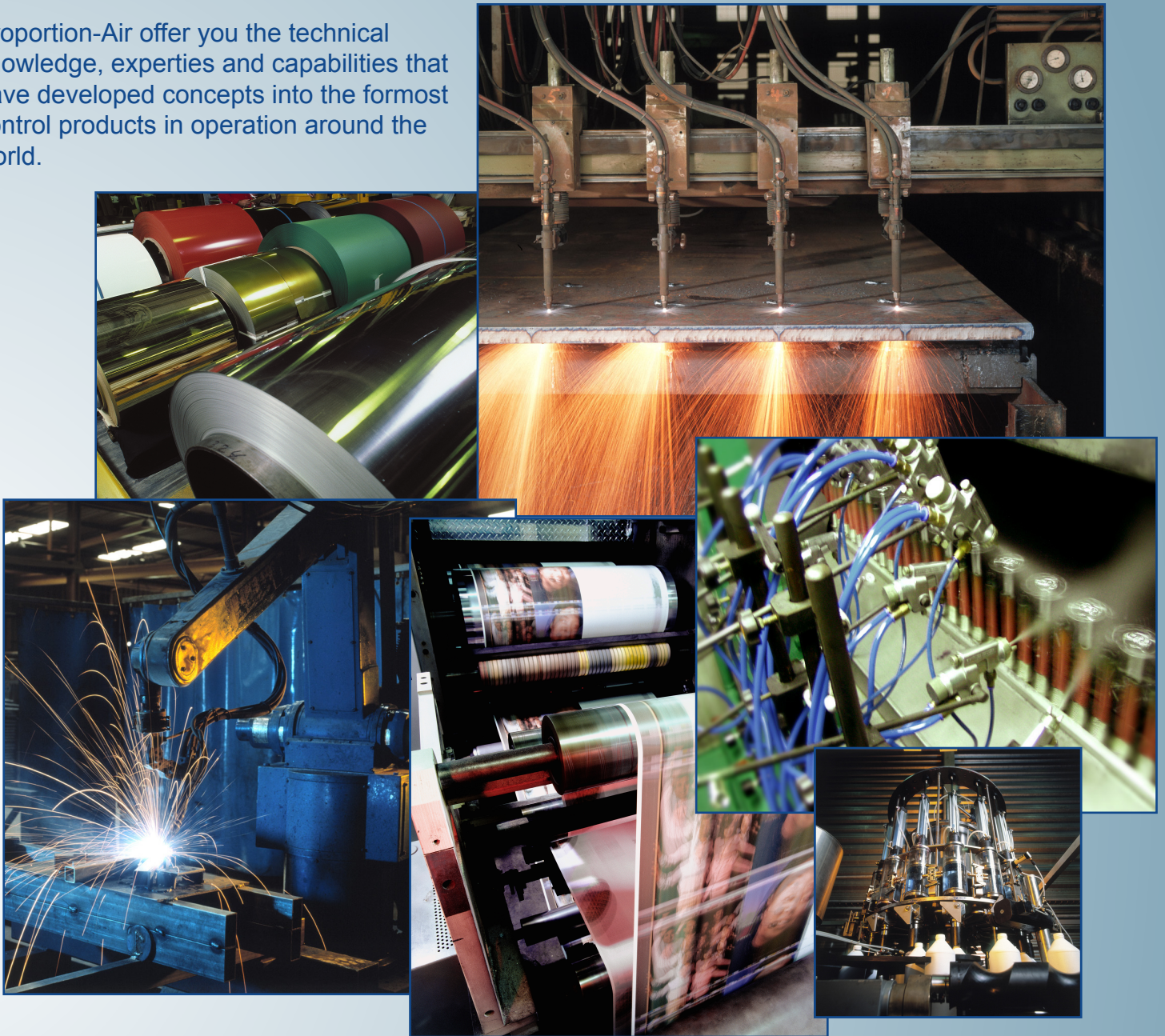

*PROPORTION-AIR, INC. 8250 N. 600 West, P.O. Box 218
McCordsville, Indiana USA 46055
Phone 317-335-2602 Fax 317-335-3853
www.proportionair.com info@proportionair.com*

WE MAKE ONE PRODUCT THOUSANDS OF WAYS

Proportion-Air products are warranted to the original purchaser only against defects in material or workmanship for one (1) year from the date of manufacture. The extent of Proportion-Air's liability under this warranty is limited to repair or replacement of the defective unit at Proportion-Air's option. Proportion-Air shall have no liability under this warranty where improper installation or filtration occurred.

All specifications are subject to change without notice. THIS WARRANTY IS GIVEN IN LIEU OF, AND BUYER HEREBY EXPRESSLY WAIVES, WARRANTIES OR LIABILITIES, EXPRESS, IMPLIED OR STATUTORY, INCLUDING WITHOUT LIMITATION ANY OBLIGATION OF PROPORTION-AIR WITH REGARD TO CONSEQUENTIAL DAMAGES, WARRANTIES OF MERCHANTABILITY, DESCRIPTION, AND FITNESS FOR A PARTICULAR PURPOSE.

.....
WARNING: Installation and use of this product should be under the supervision and control of properly qualified personnel in order to avoid the risk of injury or death.

CATALOG NO. BRMM0113